



STATIC AND DYNAMIC TESTS OF A STRENGTHENED VAULT MADE OF CALCARENITE ASHLARS

L. Cavaleri, C. Cucchiara, A. Tommaselli, G. Zingone

ABSTRACT

Maintenance of the historical monumental heritage has produced the increasing of interest in masonry structure mechanics and in research of new strengthening techniques. As a matter of fact historical structures (most of them are masonry structures) perform often a low capacity with respect to exceptional loads or a reduction of the capacity with respect to service loads because of aging. So that improving and retrofitting devices must be adopted.

Vault is a structural elements that often can be found in historical building with need of reinforcement. It is generally subjected to vertical loads that, in spite of its structural shape, can produce tensile stresses on it with a reduction of the safety level. As a consequence of vertical loads vault produces thrusting forces on walls that sum to the horizontal forces produced during the seismic events.

These factors increase the collapse probability of the walls under seismic actions, especially when the material is damaged because of aging, so a reduction of the produced thrust is desirable. On the other hand, as it often happens, the change of the service loads because of the variation of using destination (for example from residence to public) may request the reinforcement.

In this paper the devices used for the strengthening and improving of a vault of an ancient aristocratic house of Palermo, Villa Cattolica, are described. The interventions have basically the goal of improving the resistance under vertical and horizontal loading.

Through the paper is underlined the need of no change the look of the construction in order to not modify its real artistic value so, generally, only special kind of strengthening devices can be used.

In order to verify the effectiveness of the improvements, dynamic and static tests have been performed before and after the interventions. The results of static tests are mainly showed and the modifications in the structural behavior are described.

The structural analysis has been performed for the behavior prediction. Two different stages have been taken into account: the uncracked and the cracked one.

The strengthening system, made by applying CFRP strips on the upper surface of the vault, is presented through the paper.

Key words: masonry structure, vault, fiber reinforced polymer, retrofitting.

Dipartimento di Ingegneria Strutturale e Geotecnica, Università di Palermo, Viale delle Scienze 90128 Palermo, e-mail cavaleri@stru.diseg.unipa.it

INTRODUCTION

Sicily is rich of monumental buildings with very high architectural value. One of this buildings is Villa Cattolica. It was built in 1736 by Francesco Bonanno, the Roccafiiorita and Cattolica prince. It is going to house the Civic Gallery of Modern Art “Renato Guttuso” for the collection of various water-colors of modern artists.



Figure 1. Frontal view of Villa Cattolica

Villa Cattolica (Fig.1) has a masonry structure constituted by walls and vaults. Calcarenite ashlar and common mortar have been used for making masonry. Wooden wedges have been inserted between the calcarenite ashlars that constitute the vaults in order to obtain the special cylindrical shape.

The aging of this kind of structures makes often them not suitable for resisting to service loads. Furthermore, as it is known, masonry structures are often very vulnerable when they are subjected to seismic actions. In this context masonry structures must be reinforced or retrofitted for re-establishing the safety conditions.

The vault has an obvious key rule in the resistance to vertical loads. Furthermore it produces thrusting forces that sum to seismic forces so that a reduction of them is desirable.

A lot of vaults in Villa Cattolica needs to be reinforced. As a matter of fact the new use destination of Villa Cattolica as a museum has posed the problem of further service loads. More, the ancient structure has requested maintenance interventions because of aging. The interventions executed on one of these vaults is discussed through the paper. The considered vault appears to the visitors that overcome the external stairs and pass the main gate. This vault is said “a schifo” because of the flat shape of the upper zone. The geometric features are detailed in Fig. 2.

The vault carries on a wooden floor in agreement with the scheme proposed in Fig. 3-a. The lateral displacements caused by vertical loads are limited by means of opposing elements made of calcarenite (see Fig. 2).

Interventions in the area of architectural heritage often follow special guidelines (e.g. those of the Charter of Venice). Among these guidelines very significant are the requirements that these interventions should not adversely affect the character of the monument and must be reversible.

Many rehabilitation projects have been carried out but in many cases they are featured by unsatisfactory results because of the reliability of the material used, the executive criterion or the preservation of the historical identity of the buildings.

Fiber-reinforced polymer (FRP) has considerable potential of repairing and strengthening masonry elements (Triantafillou, Fardis, 1997; Foraboschi, Siviero, 1999; Avorio et al.,

1999). As a matter of fact FRP is featured by high strength to weight and stiffness to weight ratios, high durability, easy application technology, adaptation capacity to various shapes. So it gives evidence of sure advantages with respect to standard reinforcement devices. In this frame Carbon Fiber Reinforced Polymer (CFRP) strips are one of the most promising applications. CFRP strips provide solution for strengthening beams, slabs, walls, columns and other

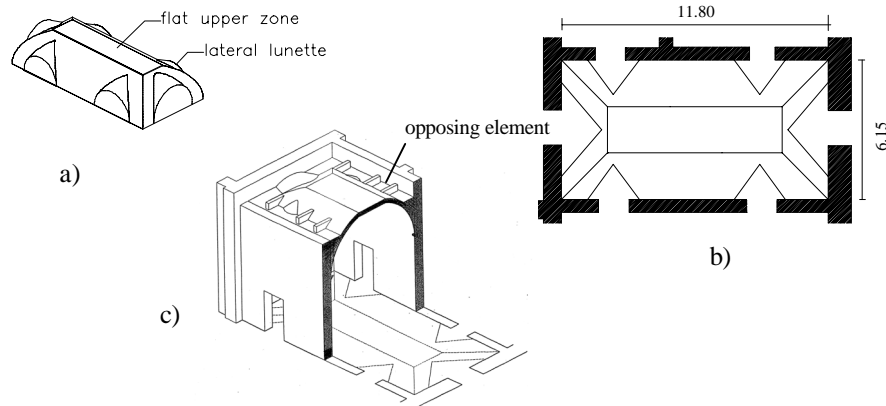

Figure 2. Geometric features of the vault: a) tridimensional extrados view; b) plane view; c) tridimensional sectional view

structural elements that are subjected to deterioration, additional service loads, or excessive deflections created by change in use, construction or design defects, code changes or retrofit.

Although their using is highly increasing and in many cases have shown the improving of the structural behavior, few experimental tests have been performed in order to clarify the numerous aspects correlated to the interaction with the masonry.

The same tests, however, have also shown that the failure is often due to the delamination of the masonry, revealing the key role of the composite interface.

The discussed vault has been reinforced by means of CFRP as it will be shown in the next paragraphs.

VAULT IMPROVING

As it is said upon the analyzed vault carries the loads transferred by a wooden floor

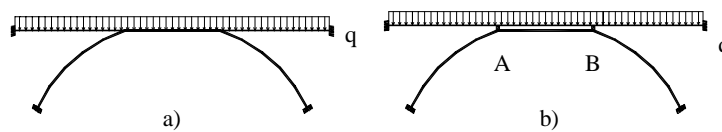

Figure 3. Loads transferring: a) before intervention; b) after intervention

(Fig.3).The state of preservation of the vault has been verified after the removal of the floor and the filling material between the vault and the floor. So the extrados has been

uncovered and the wooden wedges, used in order to give the shape to the vault, have been evidenced. The wooden wedges are placed between the ashlar along the highest curvature line. No crashed zones have been found and no alarming flexural state has been observed on the vault extrados. When the floor was removed, the loads transferring system was observed. The loads were applied directly on the upper flat zone of the vault so that flexural stresses were produced here. In order to reduce the effects of flexural stresses and the thrust on the walls the following change of loads transferring system has been designed.

Modification in the loads transferring system

It can be underlined that no interventions were possible at the intrados of the vault because of the frescos which are there, so the improving devices had to be applied on the extrados of the vault.

The transferring loads system depicted in Fig. 3/b has been realized in order to limit the flexural effects at the intrados of the upper flat zone of the vault. The wooden beams of the floor, embedded along the perimeter of the vault, have been simply supported on the point A and B indicated in Fig. 3/b. The loads of the flat zone have been transferred to the same points A and B by means of wooden beams placed between the point A and B above mentioned without any contact with the upper flat zone of the vault. In this way no distributed loads apply on the flat zone, so that the level of the bending moments can be reduced there. As a consequence of the different loads transferring system a higher safety level has been obtained. The new safety level has been evaluated by means of the limit analysis under the Heyman hypotheses (Heyman, 1982). The cinematic theorem has been applied under the hypotheses of no tensile strength and rigid material. The analysis has given a collapse multiplier with a value of 36450 N when the flat zone was loaded by gravity loads of the roof and accidental loads on one side of the vault. While the same analysis has given a collapse multiplier with a value of 47060 N when all roof gravity loads were applied on the A and B points. So an improvement greater than 30 % in the limit load has been obtained. The results are synthetically presented in Fig. 4.

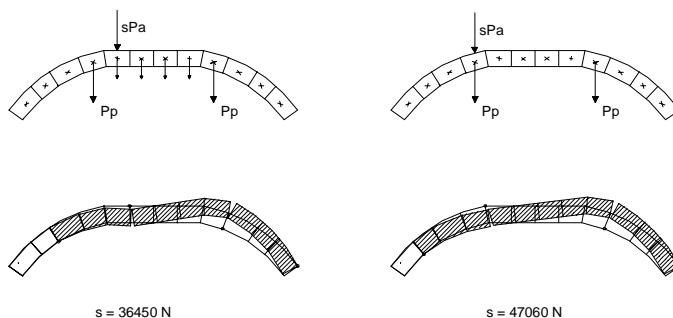

Figure 4. Limit loads and collapse mechanism: a) previous transferring loads system; b) new transferring loads system.

The improvement of the vault with respect to flexural stresses is not the only one. As a matter of fact by transferring the loads of the vault flat zone on the point A and B an

obvious reduction of the thrust has been obtained.

Application of the CFRP strips

The experimental analysis and the need of preserving the architectural values from invasive interventions, suggested the using of CFRP strips that have been displaced on the extrados surface of the vault. The used strips have the following mechanical characteristics: weight 230 g/mq, thick 0.13mm, tensile strength 3500 N/mq, Young modulus 230 kN/mmq, ultimate strain 0.015.

Strips have been applied having width 15 cm. The strips were placed along two directions

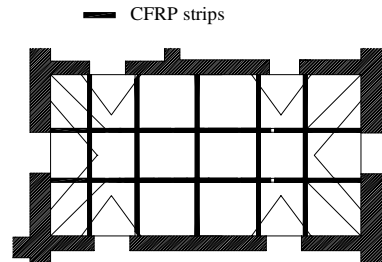

Figure 5. Position of the CFRP strips

as it is shown in Fig. 5. As an effect, the containment of the displacements along the normal direction to the vault mean surface has been obtained.

The application of the strips has been preceded by the execution of a layer 1.5-2 cm thick constituted by mortar. In this way a regular surface has been obtained. Then a layer of epoxy resin has been applied on which the strips have been placed. Finally a new layer of epoxy resin has been applied on the strips.

The strips have been properly anchored on the skewbacks. In Fig. 6 the various steps of the CFRP application are showed.

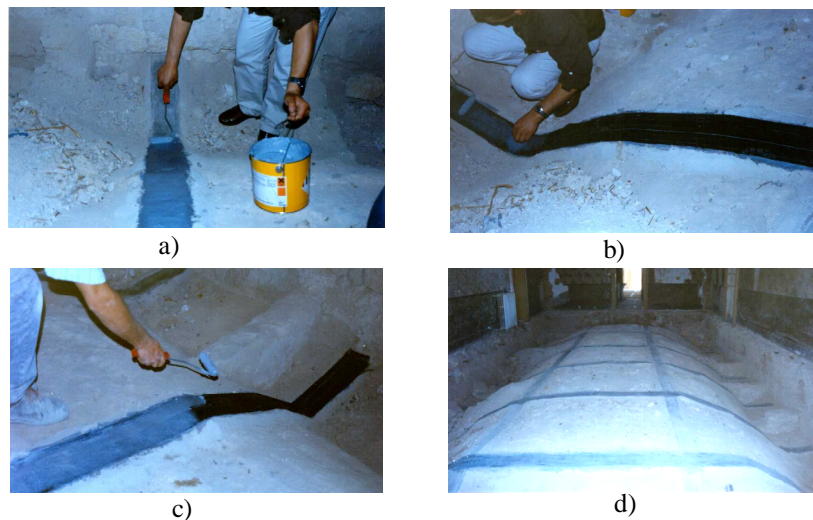

Figure 6. Sequence steps of CFRP strips application: a) epoxy resin on mortar layer; b) CFRP strips; c) epoxy resin on strips; d) vault extrados after the application of the CFRP strips

EXPERIMENTAL INVESTIGATION

A more detailed investigation has been carried out in order to evaluate the effects of the reinforcement on the vault of Villa Cattolica.

The following experimental tests have been made:

- compression laboratory tests for local mechanical evaluation of the material;
- static laboratory test on a vault under vertical loads for the evaluation of the effectiveness of the reinforcement;
- static in situ tests on the entire vault under vertical loads;
- dynamic in situ tests on the entire vault under environmental noise.

Static tests: characterization of the materials

In order to evaluate the mechanical features of the masonry composed by calcarenite ashlar and wooden wedges some ashlars used as filling material have been taken. Then two groups of walls have been made. The walls of the first group were constituted by calcarenite and poor mortar (one part of cement 325, four parts of hydrated lime, twelve parts of sand) and wooden wedges between the ashlars (Fig. 7/a). While the walls of the second group have been made with calcarenite ashlars and common mortar (constituted by one part of 325 kind cement, one part of hydrated lime and five parts of sand) (Fig.7/b). The first class characterizes the mechanics of the material along the transversal direction of vault while the second class characterizes the mechanics of material in the

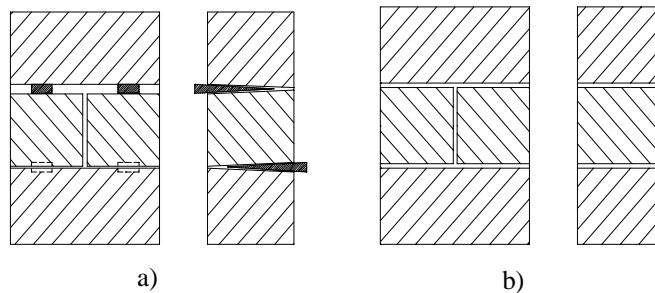

Figure 7. Specimen for compression tests: a) calcarenite ashlars, mortar and wooden wedges; b) calcarenite ashlars and mortar

longitudinal direction.

The specimen have been subjected to compression by means of a controlled displacement press.

In Fig. 8 are depicted the σ - ϵ mean curves. The similar stiffness of the specimen and the different strength and ductility can be noted.

Static tests: evaluation of global behavior

The stiffness and the flexibility of the vault have been evaluated *in situ*. Strain gauges and displacement transducers have been placed on the extrados in the upper zones of the vault. The response has been recorded before and after the variation of the loading

transmission system. In the second case lower vertical displacements and lower strains on

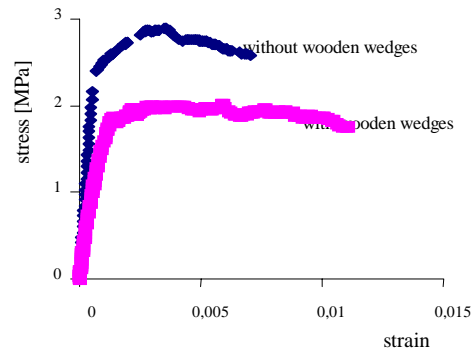

Figure 8. Results of compression tests: σ - ϵ mean curves

the vault flat zone have been observed confirming the improvement of the structural behavior.

STATIC TESTS: EVALUATION OF THE EFFECTIVENESS OF THE CFRP REINFORCEMENT

The using of CFRP for the reinforcement of masonry structures is not tested enough. So many problems must still be solved and no sufficiently analytical tested tools exist for the evaluation of the behavior of CFRP reinforced elements. Further it is not clear the way of transmitting the forces at the interface material-CFRP and the conditions for the beginning of the out of service state of the reinforcement (delamination).

In this context it is basic the carrying out of proper laboratory tests. To this aim an equipment has been designed and realized for cyclic and monotonic loading of masonry vault with different boundary conditions for the evaluation of the capacity of absorbing the thrust. This equipment allows elastic or anelastic displacements of the boundaries. A detailed description of the experimental devices can be found in (Giambanco et al., 2000; Failla et al., 2000). In the following paragraph the most significant features are described. The test equipment is composed by a fixed reinforced concrete skewback and a mobile steel one. The mobile skewback is constituted by two parts: a sliding plane and an opposing element with high stiffness springs containing a screw nail cylinder.

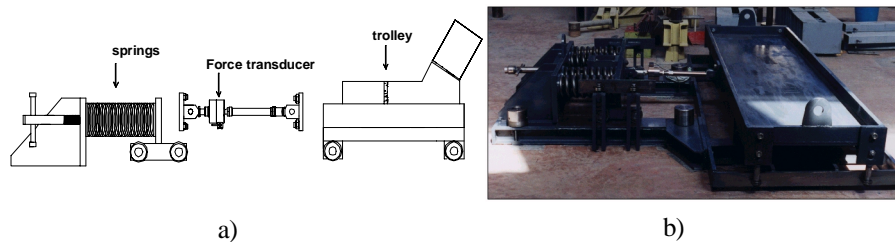

a) set-up of the mobile skewback; b) lateral view of the mobile

The two parts are connected by a force transducer with a nominal capacity of 50 kN

(Fig. 9).

In Fig.10 a vault in the test configuration can be observed.

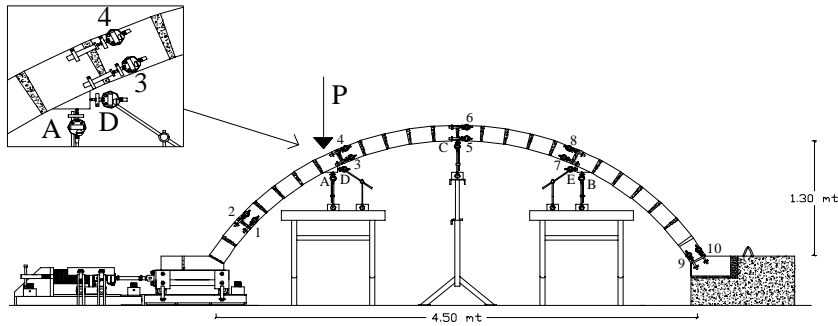

Figure 10. Complete test equipment view

The vault capacity for eccentric vertical loads applied to $\frac{1}{4}$ span (having the effects of the accidental loads) has been evaluated. This position of the loads produces the lowest capacity of the vault under vertical loads. Firstly the behavior of the unreinforced vault has been observed under increasing monotonic load. Once the collapse load has been obtained, the reinforcement has been applied and, once more, an increasing monotonic loading test has been performed and the response observed. In Fig. 11 the results of the first test is depicted. It can be observed a capacity load of 1090 daN. When the maximum load occurred the collapse mechanism depicted in Fig. 11 has been observed

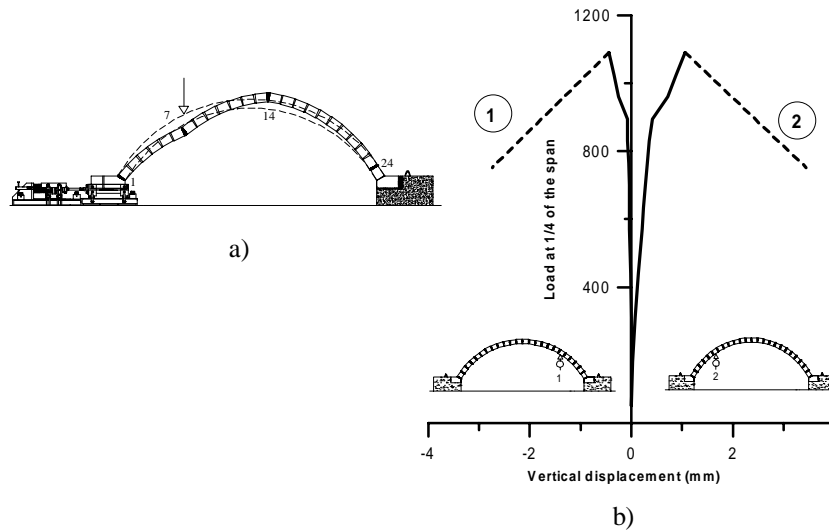

Figure 11. Unreinforced vault: a) collapse mechanism; b) load-displacement curves

with the formation of four hinges.

A new loading after the appearing of the four hinges has given a collapse value of 750 daN. The same value can be predicted by performing the limit analysis under the

hypotheses of no tensile strength and rigid material (Heyman, 1982).

The next test has provided a collapse load of 450 daN, that is smaller than previous. The reason of this result can be found in the further damage of the material in the sections where the hinges occurred.

After the first series of tests on the unreinforced vault the next step was the application of a CFRP strip (width 15 cm) on the vault extrados (Fig. 12).

The CFRP strip has been extended until the vault skewbacks and properly anchored. Then, new loading-unloading cycles have been performed. Even in this case the load have been applied to $\frac{1}{4}$ span.

The observed behavior is represented in Fig. 13 where even a comparison have been proposed with respect to the previous tests. After the unloading the structure has assumed the original geometric configuration with the closing of the cracks where the hinges occurred.

From the Fig.13 the increasing of the vault capacity load observed after the application of the CFRP strip can be derived.

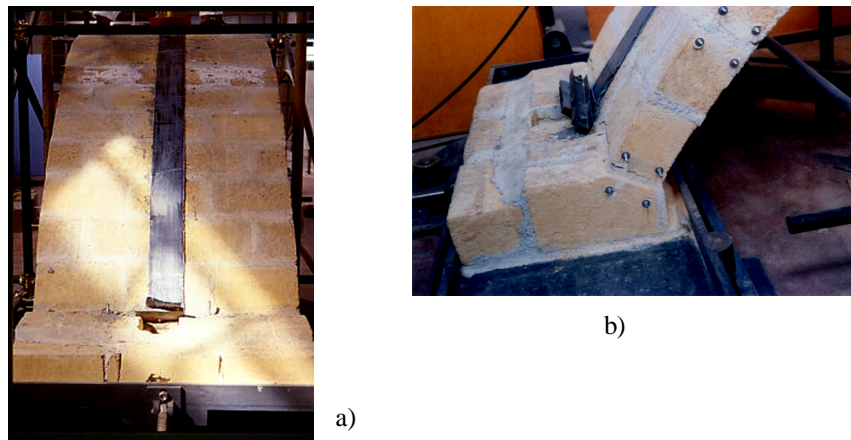

Figure 12. CFRP reinforced vault: a) global view; b) particular of anchorage with steel slab.

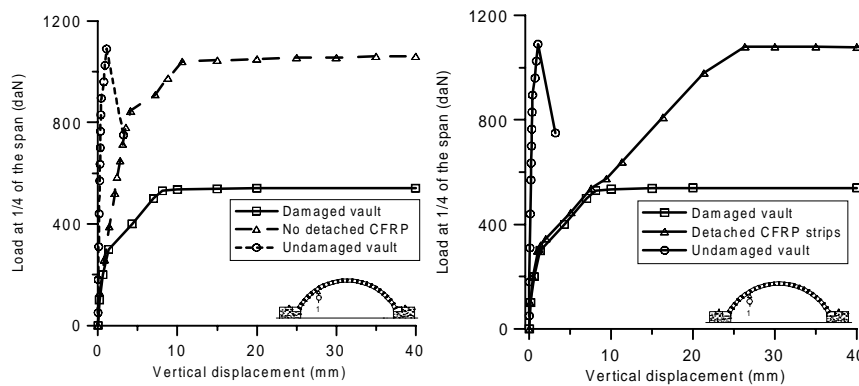

Figure 13. Comparisons between the behavior of the unreinforced and the reinforced vault

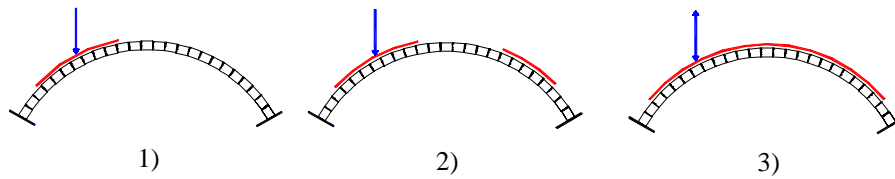

Figure 14. Separation steps of the CFRP strip

During the tests the progressive delamination of the CFRP strips have been observed. The evolution of the phenomenon has been reported in the Fig.14. After the first cycles loading-unloading the CFRP strip has detached from the vault. In spite of that the reinforcement has not reduced the beneficial effects on the structure because of the confinement. So the recovering of the capacity load has been obtained; furthermore a ductile behavior has been observed.

The tests have evidenced the need of more effective connection between the calcarenite and the CFRP strips in order to obtain a better improvement of the structure capacity. Surely an improvement is possible if different methods for fixing the strips are implemented.

The capacity produced by the application of the CFRP strip is in agreement with the capacity obtained by means of the following analytical procedure. Firstly the N-M limit domain of the section constituted by calcarenite and CFRP have to be specified (N means section normal force while M means bending moment). To this aim the constitutive law

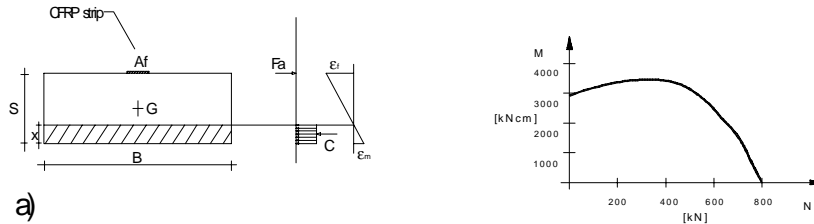

Figure 15. Evaluation of the section limit domain: a) limit stress state; b) limit domain

obtained by means of experimental tests can be adopted for the masonry area under compression.

The equilibrium equations can be derived referring to the stress state in Fig. 15.

$$\begin{cases} N_r = f_m x B - A_f \sigma_f \\ M_r = f_m x B \left(\frac{S-x}{2} \right) + A_f \sigma_f \frac{S}{2} \end{cases} \quad (1)$$

where

$$\sigma_f = E_f \varepsilon_f \quad (2)$$

is the constitutive law of the CFRP strip. For the correspondent value of the CFRP strain the hypothesis of plane section can be adopted.

After the evaluation of the limit domain the step by step elastic analysis can be performed and the hinges can be inserted in that sections where the limit conditions are reached. The analysis stops when four hinges appear.

DYNAMIC TESTS: CHARACTERIZATION OF THE VAULT

In the evaluation of the building state, the dynamic tests are widely used. As a matter of fact dynamic tests allow one to obtain more effective analytical models for the prevision of the response. Then the controlling of the damage state can be performed during the structure life.

On the vault extrados surface n. 7 accelerometers have been placed. Every accelerometer has been used for the measure of the vertical time history acceleration. The environmental noise has been used as input. The analysis of the records in the time domain and in the frequency domain has allowed to obtain data about the structural modal displacements and the stiffness, so that a realistic model has been formulated by means of an identification technique (Cavaleri, Zingone, 1999). It must be underlined that the low level of the input intensity validates the search the modal parameters. As a matter of fact the linear behavior of structure can be hypothesized in that case.

The following algorithm can be used. Said $Q(t)$ the acceleration history obtained from a fixed accelerometer, the autocorrelation function $R_{QQ}(\tau)$ and the spectral density $S_{QQ}(\omega)$ can be evaluated.

$$R_{QQ}(\tau) = E[Q(t_1)Q(t_2)]; \quad \tau = t_1 - t_2 > 0 \quad (3)$$

$$S_{QQ}(\omega) = \int_{-\infty}^{+\infty} R_{QQ}(\tau) \exp(-i\omega\tau) d\tau \quad (4)$$

In eq.(3) the $E[.]$ operator means average. Then, said $G_i(t)$ the acceleration histories obtained from each other accelerometer in the i-th measure point, the cross spectral densities

$$S_{QG_i}(\omega) = \int_{-\infty}^{+\infty} R_{QG_i}(\tau) \exp(-i\omega\tau) d\tau \quad (5)$$

can be evaluated, being

$$R_{QG_i}(\tau) = E[Q(t_1)G_i(t_2)]; \quad \tau = t_1 - t_2 > 0 \quad (6)$$

To this point the evaluation of the following coherence function

$$\gamma^2 = \frac{|S_{QG}(\omega)|^2}{S_{QQ}(\omega) \cdot S_{GG}(\omega)} \quad (7)$$

allows one the verifying of the system linear behavior.
By evaluating

$$|H_{Gi}(\omega)| = \sqrt{\frac{S_{G_iG_i}(\omega)}{S_{QQ}(\omega)}} \quad (8)$$

and

$$H_{Gi}(\omega) = \frac{S_{QG_i}(\omega)}{S_{QQ}(\omega)} = |H_{Gi}(\omega)| \exp[-i\phi(\omega)] \quad (7)$$

the modulus ratio $|H_{Gi}(\omega)|$ of the fixed acceleration history with respect to each other and the ϕ phase ratio can be evaluated for the j-th ω dominant frequency. Then, the modal shape of the system associated to the dominant j-th frequency can be derived.

By means of the acceleration histories analysis the dissipation parameters can be obtained too. More detailed informations on this procedure can be found in (Cavaleri, Zingone, 1999) and (Bendat, Piersol, 1980). After the dynamic tests an analytical model of the system can be formulated, whose mechanical features reflect the real mechanical ones. Furthermore the damage structure can be evaluated if the variation of dominant frequencies and the variation of the modal shapes are observed during the next dynamic tests, performed after a proper time period.

REFERENCES

- Avorio, A., Borri, A., Celestini, G., Corradi, M., (1999). Sperimentazione e analisi sull'utilizzo dei materiali compositi nelle costruzioni in muratura. L'Edilizia n°9/10.
- Bendat, J., S., Piersol, A., G., (1980). Engineering applications of correlation and spectral analysis. John Wiley & Sons, New York.
- Cavaleri, L., Zingone, G., (1999). Acquisizione ed analisi della risposta di una struttura muraria soggetta alle eccitazioni ambientali. Proceedings of IX Congress "L'ingegneria Sismica in Italia", Torino, Italy.
- Charter of Venice, (1964). Decision and Resolution. Proceedings of the 2nd International Congress for Architects and Technicians of Historic Monuments, Venice.
- Di Tommaso, A., Foraboschi, P., (1995). Armature in compositi fibrosi a matrice polimerica per il conglomerato cementizio. L'Edilizia n° 9/10.
- Failla, A., Cucchiara, C., Accardi, M., (2000). Experimental investigation on the behaviour of cylindrical vaults in calcarenite ashlar and bed joint mortar. 12th International Brick/Block Masonry Conference, Madrid.
- Foraboschi, P., Siviero, E., (1999). Volte in muratura con rinforzi in FRP. L'Edilizia n°9/10.
- Giambanco, G., Failla, A., Cucchiara, C., (2000). Numerical modelling of masonry arches. 12th International Brick/Block Masonry Conference, Madrid.
- Heyman, J., (1982). The masonry arch. E. H. Ltd., New York.
- Triantafyllou, T. C., Fardis, M. N., (1997). Strengthening of historic masonry structures with composite materials. Materials and Structures (Rilem, Francia).