



TENSILE STRENGTH OF BRICK MASONRY

A.R. Santhakumar¹, S.Ashok²

ABSTRACT

Normally Tensile strength of brick masonry is neglected assuming that the strength is negligible. However in certain circumstances the tensile strength of brickwork is a necessity especially, if we have to avoid either an RC Band or reinforcements. This is required in corrosion prone zones, such as coastal areas, splash zones, etc.

In this paper an experimental method to ascertain the tensile strength of the brick masonry is suggested. The strength is a function of the stress variation across mortar joint varying from uniform compression to uniform tension.

The test series shows an interaction relationship between the tensile strength of brick work and maximum to minimum stress ratio across the wall.

The strength is also a function of strength of mortar .The series of tests shows the need for interlocking blocks to achieve desired tensile strength.

Key words: Brick work, Tensile strength, Bending strength interaction curve, Cantilever span

¹Dean, Anna University, Chennai – 600 025, INDIA. Email: santhaar@hotmail.com

²MS Research Scholar, Anna University, Chennai, INDIA.
Email: ashok@internetdrive.com

INTRODUCTION

Brick has been used in building construction since civilization of mankind. It is one of the least expensive materials made from clay and used in a variety of architectural, building and industrial applications. It is probably one of the most durable materials that can withstand aggressive environment much better than many other building materials. Bricks perform very well in compression, yet its tensile strength is almost negligible, which makes the masonry structure more vulnerable, during earthquake situations, as experienced in the Bhuj, India on Jan 26, 2001. This paper attempts to investigate the load moment interaction in a brick pillar and thereby highlighting the need for tensile strength in brick masonry.

Comparison with Concrete

Concrete, is reinforced with steel, in order to carry tensile load. Unfortunately, there is no practice of manufacture of reinforced bricks, to improve the tensile strength in India. The tensile strength solely depends upon the strength of the mortar which is the weakest link, in masonry. A testing methodology is identified in this paper, to evaluate the true tensile capacity of the brick masonry.

Test Procedure

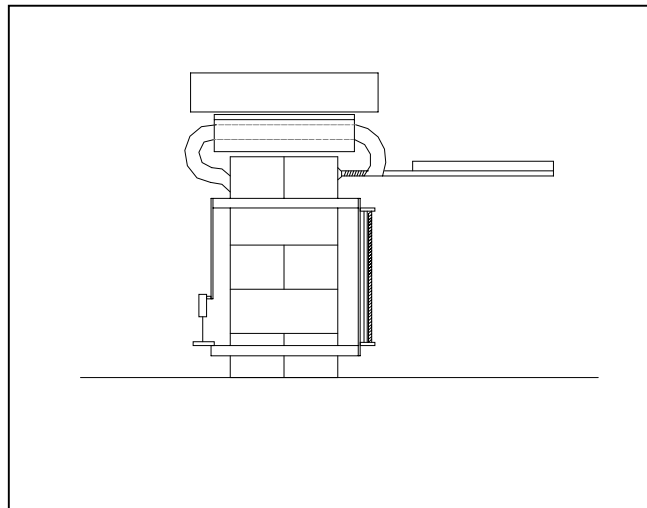

Fig 1. Test Set - up

The Test set-up is shown in the Fig.1 and Fig. 2. It consists of 230mm x 230mm brick pillar of height 450mm/340mm, to which a 'C' clamp is fixed on the top, to facilitate applying a moment, while a separate arrangement is made to facilitate axial loading, as shown in Fig.1.



Figure 2. Test set-up photograph

Load Application

Loading is applied by the two methods.

1. Axial load is first applied gradually, till it reaches the desired value and then kept as constant.
2. Incremental Loading is done on the cantilever arrangement, till the specimen fails.

By this methodology (See Fig. 3), the ultimate load-moment capacity of an axially loaded a specimen can be found.

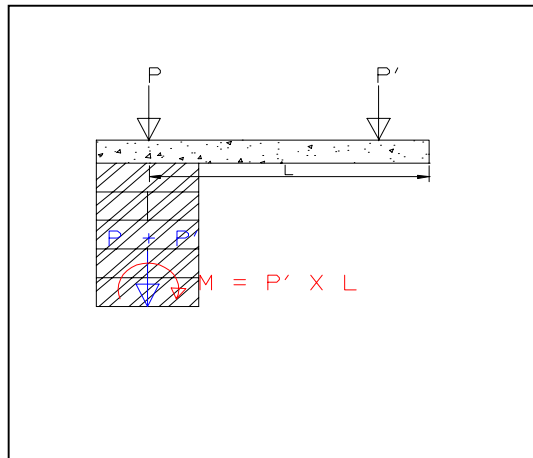

Figure 3. Load Application - Conceptual diagram

Measurement of Strain

To study the load – deformation relation, it is essential to measure the strain, in the brick work both during axial loading and applying moment. A special mechanical strain gauge was designed and fabricated to measure strain in the brick specimen(see Fig.4).

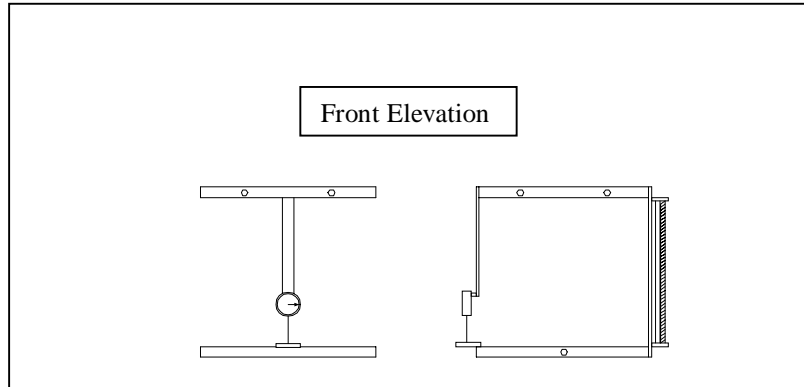

Figure 4. Mechanical Strain Gauge

The top and bottom frame of strain gauge, are fixed to the brick pillar (see Fig.2). The top frame is fixed on all four sides with screws, while the bottom frame is fixed only on two (opposite) sides, there by allowing rotation. The spring and bar arrangement on one side forms a hinge while the opposite side moves freely, in proportion to the strain, which is measured using a dial gauge.

The strain measured at the end, is twice the strain at the centre of the specimen, as it is a triangular variation.

Hence, strain along the central axis of the specimen is given as

$$\epsilon = \delta L / 2L, \quad \dots(1)$$

where

δL	=	change in length (from dial guage)
L	=	Guage length i.e.,320 mm
ϵ	=	Strain

BEHAVIOUR OF BRICK SPECIMENS

The Specimen details and their failure pattern is given in Table 1. A typical curve of load vs strain is shown in Fig 5. A sudden change in slope of the curve is seen as soon as the cantilever loading commenced.

A load vs moment interaction curve is drawn, using the results of the series of tests conducted. This is shown in Fig.6 and Fig. 7. The failure patterns can be seen in Fig.8, Fig. 9, Fig 10 and Fig 11.

Table 1. Specimen Details

S.No	Name	Load (N)	Moment (N mm)	Failure Between
1	450M1	650	292500	Brick and Concrete surface at the bottom level
2	450M2	18431	310500	Brick and Concrete surface at the bottom level
3	340M3	1440	597600	II and III level Bricks
4	340M4	6143	601750	II and III level Bricks
5	450M5	4733	647400	I and II level Bricks
6	450M6	7973	9337500	I and II level Bricks
7	340M7	90000	0	Vertical cracks on all four sides

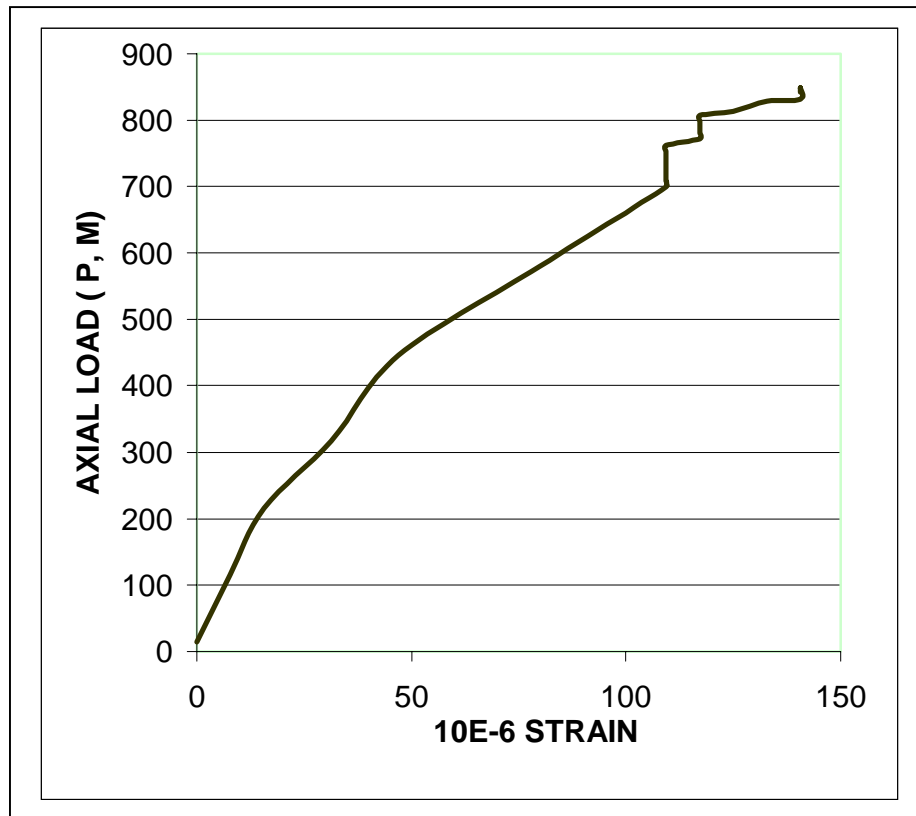

Figure 5. Load Vs Strain

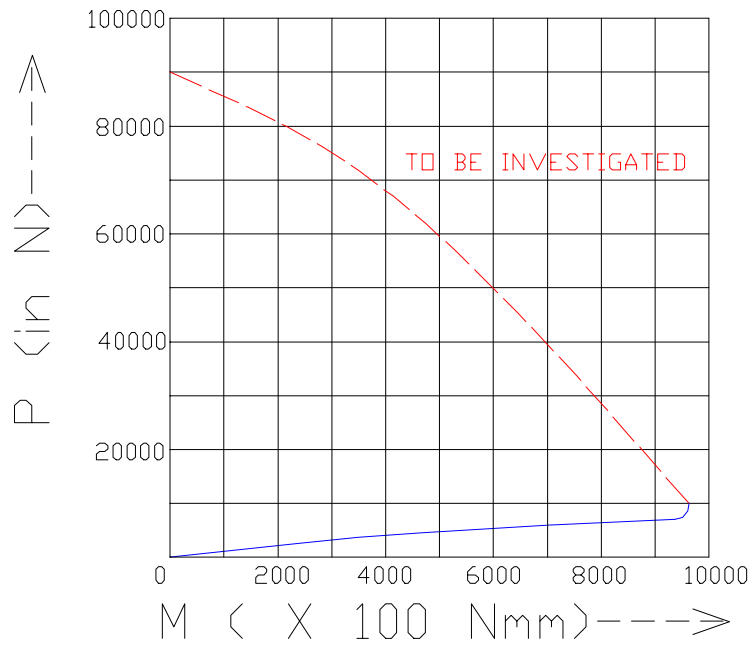

Figure 6. Load Vs Moment

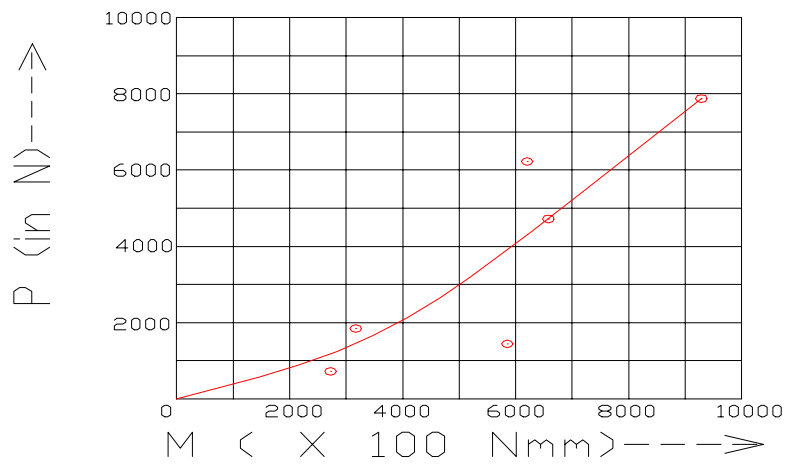

Figure 7. Load Vs Moment (enlarged scale)

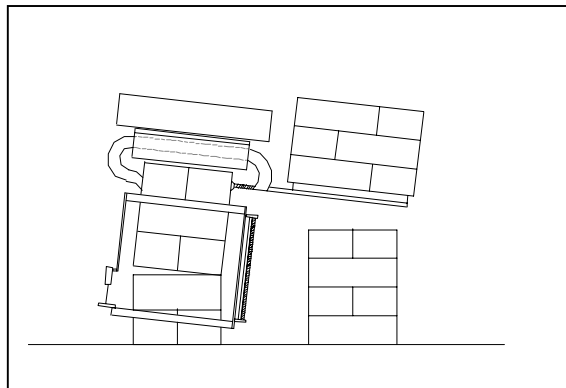

Figure 8. Failure at the mid level

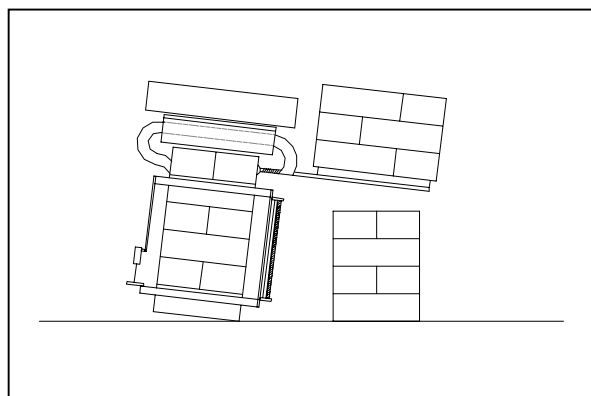

Figure 9. Failure at the bottom level



Fig.10. Specimen After Failure



Figure 11. Specimen after failure (another View)



Figure 12. Specimen after Failure(close up).

RESULTS AND DISCUSSION

The Load vs Moment Interaction curve (Fig.7) can serve as guidelines for designing safe masonry structures. The same is explained below.

Consider an axial load of 1000N acting on the brick pillar of size 230 mm X 230mm, over which a cantilever beam of length 'L' and cross section of 230 mm X 100 mm, rests as shown in fig.11.

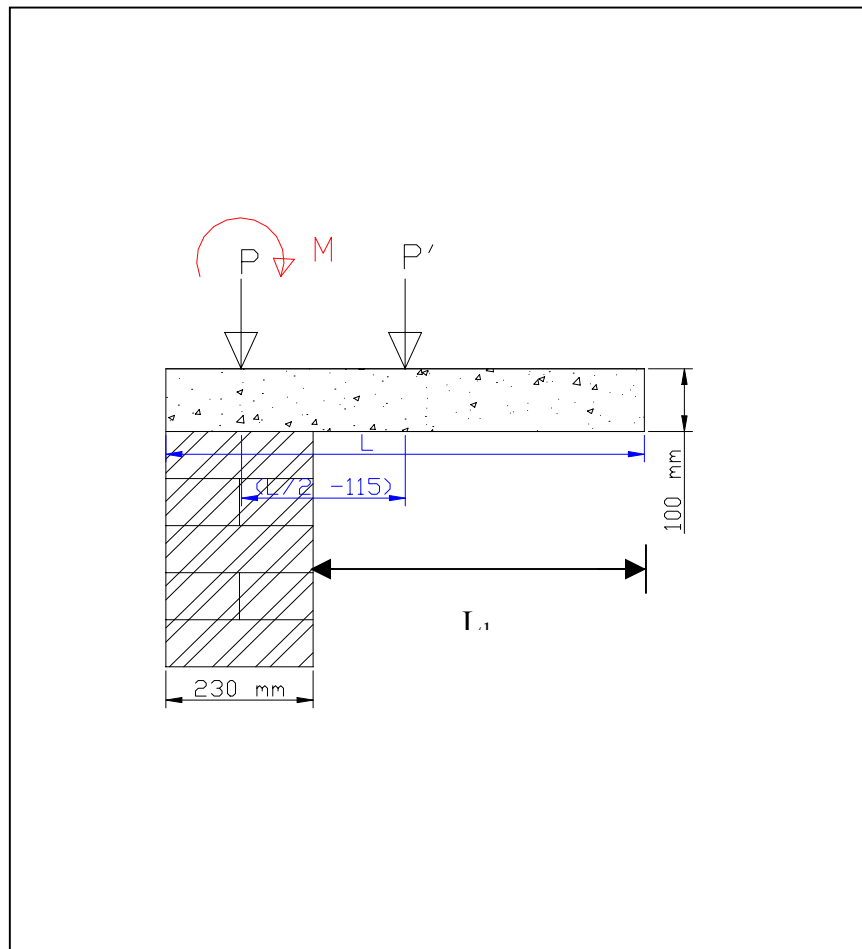

Figure 13. RCC Slab Resting on a Brick Pillar

The safe length of the cantilever can be determined (Ref eqn. 3) by equating the moment due to the cantilever beam, to the factored moment capacity (factor of safety = 1.5), which can be got from the Load vs Moment Interaction curve (fig 6), for a desired axial load.

$$\left(\frac{M_u}{1.5}\right) = (23 \times 100 \times L) \times 2500 \times 10^{-8} \left(\left(\frac{L}{2}\right) - 115\right) \quad \dots 2$$

$$L^2 - 230L - 2.3188M_u = 0 \quad \dots 3$$

$$L = \left(\frac{230 + \sqrt{52900 + 9.2572 M_u}}{2}\right) \quad \dots 4$$

$$L_1 = L - 230 \quad \dots 5$$

Where, M_u = Ultimate Moment, L = Actual Length of the RCC Slab, L_1 = Safe Span of the Cantilever.

The safe span (L_1) for the cantilever considered in the above case (ref Fig.9) for various axial loads are given in Table 2.

Table No. 2 Safe Span of Cantilever for various Axial Loads.

Axial Load (N)	Safe Moment(Nmm)	Safe Span of the Cantilever (L_1)(mm)
1000	200000	574.9891
2000	325000	759.8557
3000	450000	911.9664
4000	575000	1044.287
5000	685000	1149.326
6000	775000	1229.175
7000	885000	1320.751
8000	940000	1364.414

CONCLUSION

1. This paper suggests a method of finding load – moment interaction curve for a typical brick pillar.
2. This paper quantifies the cantilever span that can safely be adopted for different axial load levels on the brick column.
3. This paper brings out the need for introducing techniques for enhancing tensile strength of brickwork.