



## TRIDIMENSIONAL ANALYSIS OF TALL BUILDINGS IN MASONRY STRUCTURES

Palacio, K. (1) e Silva, R.M. (2)

### ABSTRACT

This work deals with the implementation of a program, which is based on CAD, to analyze tall buildings in masonry structures. The program considers the use of thin-walled elements of open cross section to represent structural walls, beams with or without torsion strength to represent lintels, and floors as rigid diaphragms. The thin-walled elements of open-section, which represent shear walls, are analyzed by using Vlassov's bending and torsion theory, where are taken into account the warping and bimoment. This program also enables us to evaluate the effect of shear deformation in the structural walls, considers the interaction among them, and elastic ground support for foundation by adding spring supports. The structural analysis is performed on first and second order effect. It uses the series sub-structuring technique, wherein the stiffness matrices and load vector of each floor are formed and then they are condensed into the coordinates of the inferior floor until it reaches the first floor ( base).

**Key words:** Analysis program, Masonry structures, Tall buildings, Shear walls, Thin-walled elements of open cross section, CAD resources.

(1) Civil Engineer, MSc.

Departamento de Engenharia de Estruturas  
Universidade Federal de Minas Gerais (UFMG)  
Avenida do Contorno, 842, 2 andar - Centro  
Belo Horizonte MG 30110-60  
BRASIL  
e-mail: [kesio@dees.ufmg.br](mailto:kesio@dees.ufmg.br)

(2) Adjunct Professor , Dr.

Departamento de Engenharia de Estruturas  
Universidade Federal de Minas Gerais (UFMG)  
Avenida do Contorno, 842, 2 andar - Centro  
Belo Horizonte MG 30110-60  
BRASIL  
e-mail: [roberto@dees.ufmg.br](mailto:roberto@dees.ufmg.br)

## **INTRODUCTION**

The use of constructive system in structural masonry for multistory buildings has been used largely in the most part of the world due to their uncountable vantages when compared to traditional constructive systems.

In tall buildings it is essential to analyze its strength to lateral loads caused mainly by actions of wind and seisms. The existent techniques for structural analysis in buildings of masonry are many. Some of them involve more simplified calculuses, other procedures more refined, as for example, the finite-element method (FEM) and matrix analysis. In spite of being more accurate, the use of FEM is not always justified because of involved costs and time in processing.

The distribution of actions among the walls is one of the greatest problems to be faced by the designer during the process of structural analysis of a building in masonry structures. The usual procedures to perform this operation and therefore the determination of stress are simplified. In most cases, these procedures become complicated in proportion to the increase of complexity of the structure, as for example, the non-existence of structural symmetry. Besides, the use of these procedures normally requires from the designer good skills with structural projects.

The goal of this work consists in the development of pre- and postprocessor program, in Delphi 4<sup>TM</sup> with CAD resources, named MASAN 01, to perform tridimensional analysis in masonry structures. To perform the analysis MASAN 01 uses another program denominated CEASO 01, which was developed and tested by [1] and [2] to perform tridimensional analysis in tall buildings of reinforced concrete with resistant cores. On this processing program the resistant cores are modeled as thin-walled member of cross open section, to which apply the Vlassov's bending-torsion theory. The resistant cores can still be partially closed by special beams on the level of floors (lintels).

As the structures of structural masonry are formed by tridimensional association of elements of wall, having on horizontal cut a cross open section of thin walls, thus one can model them as members of open section. With relation to span of walls with openings (lintels), they can be modeled by members of beam.

CEASO 01 performs linear analysis and includes P-delta for second order effect as well as spring supports; concrete slabs working as rigid diaphragms; bending of walls and lintels being governed by Timoshenko's theory, where the distortion of the cross section of member is considered.

## **CEASO 01 PROGRAM**

The program CEASO 01 was developed as part of the dissertation "Effect of Shear Deformation in the Analysis of Multistory Buildings", from [1]. The goal of this study was to perform structural analysis of multistory buildings of reinforced concrete with resistant cores, taking into account shear deformation in these elements as well as in columns.

The abbreviation CEASO comes from “Cálculo de Edifícios Altos em Teoria de Segunda Ordem” (Analysis of Tall buildings in Second Order Effect), program developed by [3] and it served as base for the program CEASO 01.

This latter one analyzes the interaction between resistant cores and plane frames or tridimensional structures of tall buildings. Defined are nine types of elements: five types of vertical elements, two types of horizontal elements, and two types of diagonal elements. The elements admitted by program are:

ELM-01: vertical member of truss (it has two displacements of translation in axial direction at each end).

ELM-02: it is a column of plane frame that has flexure in only a plane.

ELM-03: it is a column of space frame that has flexure in two planes.

ELM-04: it is also a column of space frame but with strength to torsion.

ELM-05: this is the thin-walled element with open cross section, which represent shear wall elements. It has seven displacements at each end, where the last displacement represents the rate of twist, which introduces the force termed the bimoment.

ELM-06: it is a beam member without torsion strength

ELM-07: it is a beam member with torsion strength

ELM-08: it is diagonal member of plane truss (it links two planes of floor)

ELM-09: it is diagonal member of plane frame (it has flexure in only a plane)

It is admitted that floor has infinite rigidity in its own plane, which allows horizontal translations and the rotation of floor about a vertical axis. Consequently, it is not discretized into finite elements and loads have to be applied to the floors directly on vertical elements (columns and shear walls)

The program allows analysis in first and second order effects where the formation of stiffness matrix of shear wall in second order effects is done according to the process developed by [3], which uses numerical technique aided by the ODEPACK subroutines that was developed by [4]. It uses the series sub-structuring technique, wherein the stiffness matrices and load vector of each floor are formed and then they are condensed into the coordinates of the inferior floor until it reaches the first floor (base).

On CEASO 01, the flexure as much of shear walls (ELM-05) as columns (ELM-02, ELM-03, and ELM-04) about the y and z axes (being yz the horizontal plane) is governed by Timoshenko's theory wherein the distortion of cross section of the member is considered. Thus, the transversal displacement of axis of the member is related to flexure and shear force.

The program also allows to consider rigid-end factor (length of columns that is embedded in slab intersections), eccentricities of project, and flexibility of foundations by adding spring supports to the end of vertical elements that are connected to the foundation. The deformations these materials, which constitute the structure, are linear-elastic.

#### Description of the Elements for Analysis of Masonry Structures

For the analysis of buildings in structural masonry, the program CEASO 01 lives up to all the conditions, providing all the necessary elements for the modeling this kind of structure. Thus, the bearing walls and the lintels may be modeled respectively by ELM-05, and ELM-06 or ELM-07.

Below are the models and resources that will represent the structural elements that will compose the structures of masonry.

### **Bearing Wall**

It is represented by ELM-05 element, a thin-walled element of open cross section to which applies the considerations of Vlassov's bending and torsion theory. This is a frame element with seven displacements at each end and was developed by [5]. The displacements are: translations in direction of x, y, and z axes, rotations about these axes and warping. The global and local coordinate system of displacements of these elements is shown in Figure 1.

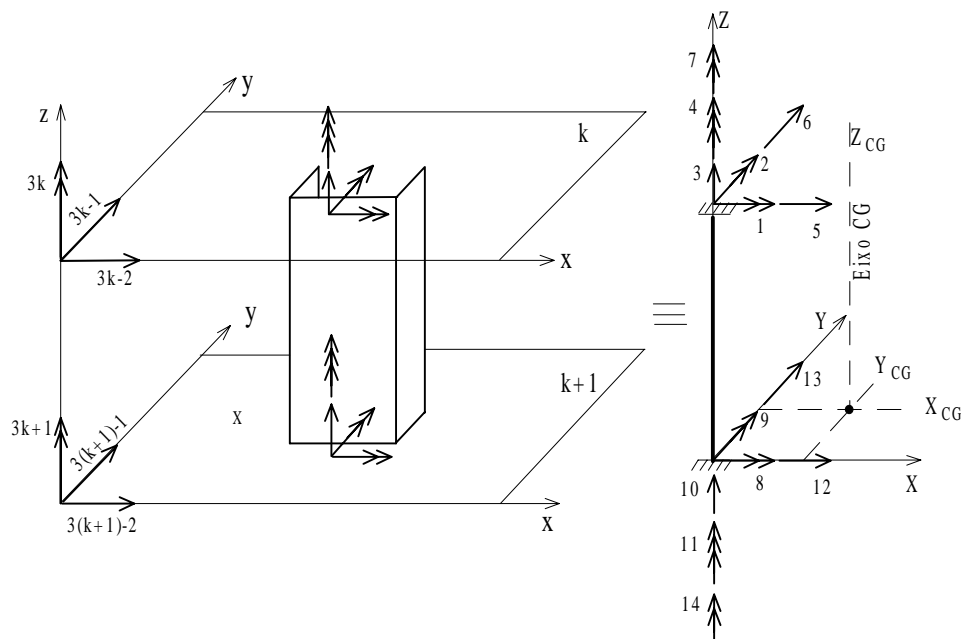

Figure 1 – Coordinate System of Displacements of ELM-05 Element

Thin-walled elements with open cross section, which constitutes the bearing walls of masonry, are analyzed using the bending and torsion theory. In short, the walls of open section are treated like linear members, taking into account the consideration of warping as an additional degree of freedom to obtain its stiffness matrix. This degree of freedom introduces a new force, termed the bimoment, which is responsible for additional normal stress. To calculate the geometry properties of the wall, its cross section is discretized into finite elements which allows computing stress and displacements as warping and horizontal translations of the section.

## Lintels

Lintels elements are structural components that will connect to shear wall elements, allowing the interaction among them. They are represented by ELM-06 or ELM-07 elements, beam elements with or without torsion strength, respectively. In Figure 2 is shown the coordinate system for lintels without torsion strength. For those with torsion strength the coordinate system is shown in figure 3.

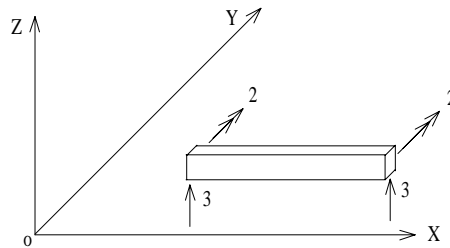

Figure 2 – Coordinate System of Displacements of ELM-06 Element

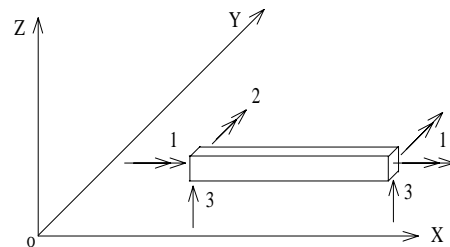

Figure 3 – Coordinate System of Displacements of ELM-07 Element

## Floors

As in the structures of reinforced concrete, in the buildings of structural masonry the slabs form with walls and lintels a monolithic structure, which due to its great stiffness in its own plane, the structure has a unique behavior in its own plane. That is, each joint on the floor is constrained to displace in the horizontal plane in accordance with a master joint; but the out of plane displacements are assumed to be independent of the floor motion. Thus, due to this high stiffness in its own plane, slabs of concrete can be simulated as rigid diaphragms.

The simulation of rigid diaphragms, Figure 4, imposes that all joints of a XY plane don't have relative displacements among them. Each plane is represented by a master joint whose location is arbitrary in this plane. All the others joints of plane are connected rigidly to the master joint that displace in the XY plane in accordance with this special joint.

The use of rigid diaphragm has the following advantages:

- reduction in the number of equations in the system to be solved that usually result in increased computational efficiency;
- elimination of the numerical-accuracy problems and other technique of modeling;
- avoid the use of plate finite element;
- very useful in the analysis of wind in tall buildings.

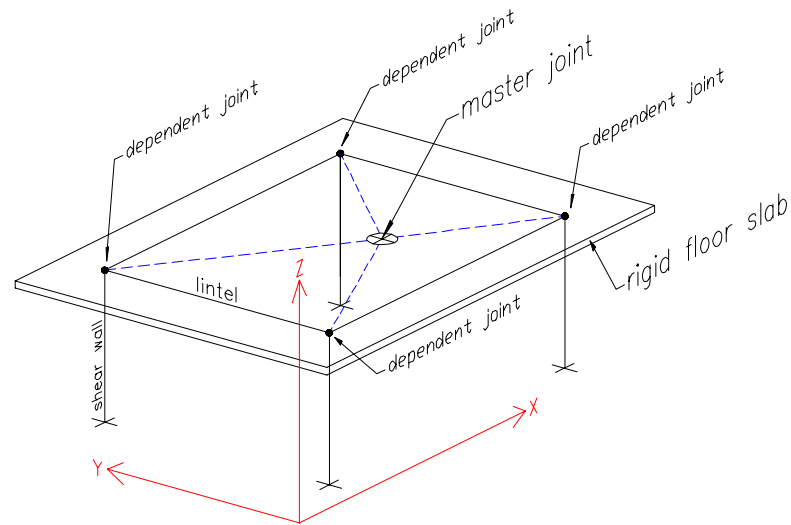

Figure 4 - Floor as a System of Rigid Diaphragm

### **Features of MASAN 01 Program**

One of the goals when MASAN 01 program started to be designed was to develop a program that could allow rapid data generation and results interpretation. To achieve these goals it has been used visual program of development, Delphi 4.0™, running under Windows™, to develop MASAN 01. This program plays simultaneously two roles: pre- and postprocessor. Below are shown the main features of this program:

### **Windows Environment**

Running under Windows this program uses all the advantage that this environment can offer, as for example: work with many superimposed windows of data (becoming the input data and the analysis of results easy) and fast browse, etc.

### **Graphic Input**

The drawing of structural elements is made in CAD environment, directly on the architectonic plan (via DXF file). One can still define the structural elements just drawing the average line of walls as well as lintels.

The integrated CAD environment of MASAN 01 has all the facilities of a standard CAD, as tools for snap to points, organization of drawing in different levels using layers, tools to draw basic objects (line, polyline, text, circle), and editing tools.

### **Total Integration**

After processing the analysis, forces, stress, and displacements remain available for user's analysis who don't worry about generating files or doing any procedure like that because the integration is total between the analyzed model and results. At anytime one can modify the drawing of the structure, adding or deleting floors, walls or lintels.

### **Output of Results**

MASAN 01 gives the following results:

- Reports for data input as geometry data, materials and loading for each structural element;
- Reports for output of results as displacements, forces and stress for each structural element;
- Diagrams of stress and displacements for walls;
- Charts of displacements and forces for all the structural elements.

### **EXAMPLE**

The example bellow was analyzed by [6] and consists of a four-story building and floor to floor height of 2800 mm, whose plan is shown in Figure 5. On the plan of Figure 5 it was changed the position and number of windows in order to simplify the model of analysis as well as the generation of results (Figure 6).

All walls were constructed by structural blocks of concrete with thickness of 14 cm and it was assumed  $E = 10.5 \text{ KN/mm}^2$  and  $G = 4.375 \text{ KN/mm}^2$  for longitudinal and shearing deformation moduli, respectively.

All walls were subjected to a lateral load,  $q = 0.010 \text{ KN/mm}$ , in Y-direction, whose distribution is uniform throughout its height. The considered vertical loads were: own weight of wall,  $w = 0.20 \text{E}^{-7} \text{ KN/mm}^3$ , and loads from floor of  $0.010 \text{ KN/mm}$  acting on each floor.

With the intention to check the results provided by the MASAN 01 program, it was used ANSYS program, which is a trustful program of analysis in finite element and largely used, to make the comparative analysis.

Since the model of discretization is adequate, FEM is quite accurate as it has already demonstrated by many investigators by comparing the numerical solutions of this method with the analytical solutions and experimental results [6]. So it was considered FEM solution as "exact" in the analysis of walls after having been checked if its mesh used in the discretization was adequate. In both programs it was used the resource of rigid-diaphragm to simulate the floors.

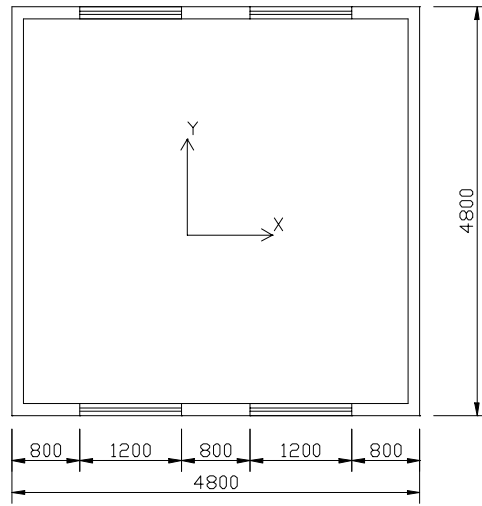

Figure 5 – Original Model Analyzed by [6]

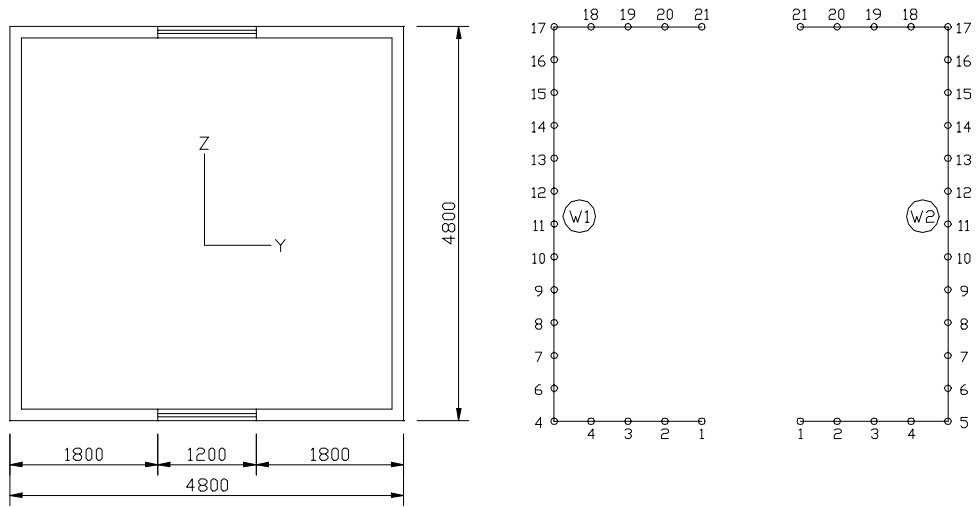

Figure 6 – Symmetrical Model and its Discretization in MASAN 01



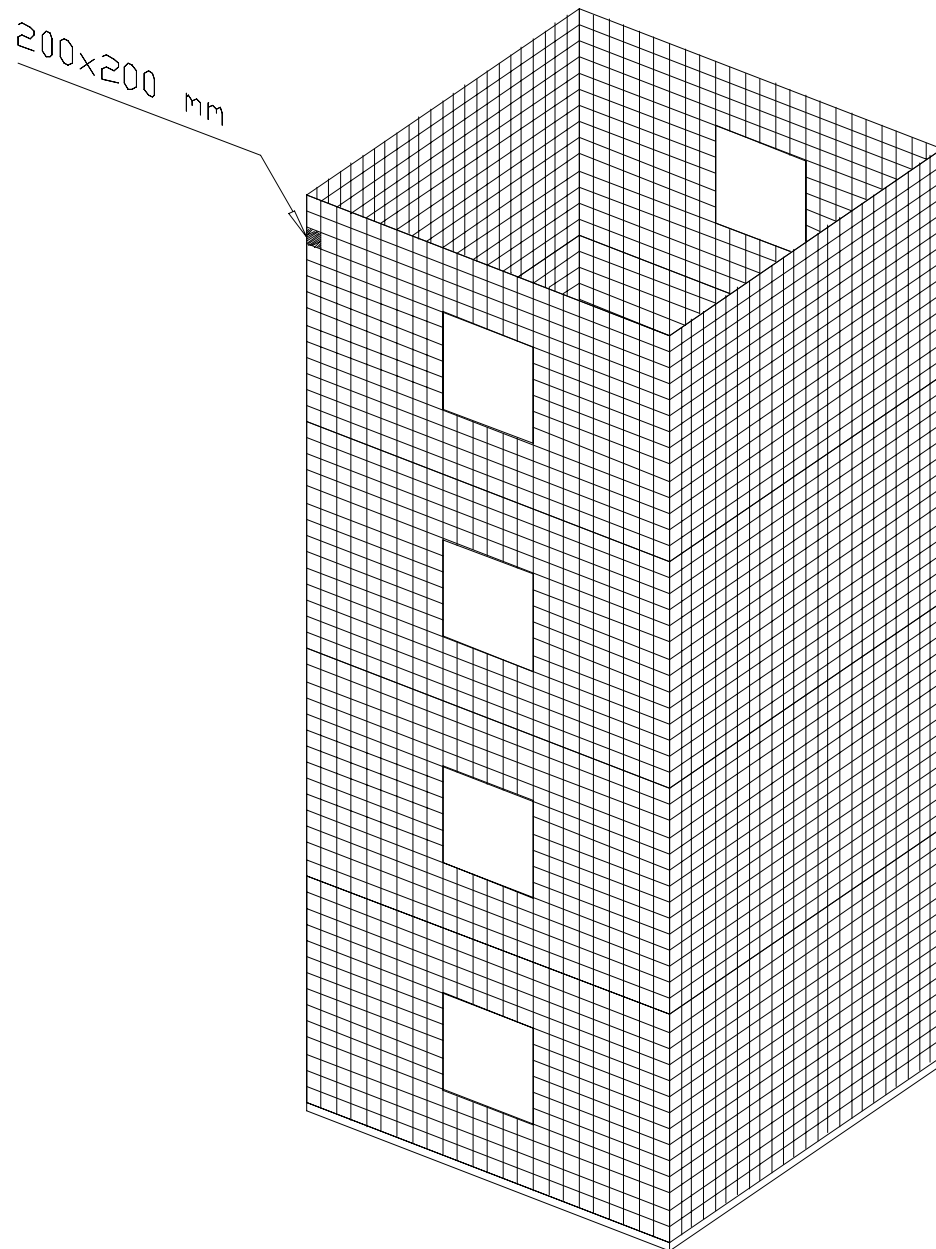

Figure 7 – Discretization of the Model in ANSYS Program

With relation to ANSYS analysis it was used shell element of four nodes to discretize the model (it was discretized in elements of 200x200 mm as shown in Figure 7). This element has six degrees of freedom at each node: translations in the nodal x, y, and z directions and rotations about the nodal x, y, and z-axes. On MASAN 01 the analysis was performed in first order effect, considering the effect of shear deformation in walls as well as lintels. For lintels were still considered the strength to torsion.

Normal stress is a parameter of great importance in the analysis of masonry structures. So it is shown in Table 1 the results obtained by ANSYS and MASAN 01 for the model analyzed. The results showed in Table 1 refer to stress on the base of structure and as the model is symmetric, it is shown in Table 1 just the stress of W1 wall.

Table 1 – Comparative Result

Node	Normal stress ( $-10^{-4}$ KN/mm <sup>2</sup> )		Variation (%)
	ANSYS	MASAN 01	
<b>1</b>	<b>2.5954</b>	<b>3.7894</b>	<b>46.00</b>
2	3.9857	3.7888	-4.94
3	3.9572	3.7882	-4.27
4	3.9245	3.7875	-3.49
<b>5</b>	<b>5.4010</b>	<b>3.7894</b>	<b>-29.84</b>
6	4.5659	4.0846	-10.54
7	4.5069	4.3823	-2.76
8	4.6963	4.6801	-0.34
9	4.9325	4.9778	0.92
10	5.1778	5.2755	1.89
11	5.4270	5.5732	2.69
12	5.6884	5.8709	3.21
13	5.9826	6.1686	3.11
14	6.3555	6.4664	1.74
15	6.9243	6.7641	-2.31
16	8.1435	7.0618	-13.28
<b>17</b>	<b>14.1470</b>	<b>7.3595</b>	<b>-47.98</b>
18	8.8080	7.3538	-16.51
19	7.6464	7.3480	-3.90
20	6.9709	7.3423	5.33
<b>21</b>	<b>4.2970</b>	<b>7.3365</b>	<b>70.74</b>

As one can see from Table 1, the stress evaluated by MASAN 01 have good conformability to ANSYS results, having only differences of 1% to 5% in those nodes that are not located on the sharp corner as well as near their neighborhood. Nodes that are on these conditions, as case of 1, 5, 17, and 21 nodes, have problems of stress singularity, which cause a sudden stress rise on them [7]. Thus, they don't represent the correct distribution of stress in the region near the junction of the walls as well as sharp corners. Besides, as it was said, the evaluation of stress in MASAN 01 program incorporates

another term, which is based on the effect of bimoment, and it causes the increase of stress, changing the behavior of distribution of stress along the section of wall.

## CONCLUSION

The analysis program proposed to analyze masonry structures, which uses mathematical model based on Vlassov's bending and torsion theory, has shown that can perform these analyses with great accuracy. Besides, this program was designed to analyze large structures where the use of finite element may not be adequate due to the computational effort that it requires to perform these structures as well as time processing.

## REFERENCES

1. Matias JR., I.G., (1997). "Análise não Linear de Estruturas Tridimensionais de Edifícios Altos com Núcleos Resistentes sobre Fundações Flexíveis," Dissertação de Mestrado, Escola de Engenharia de São Carlos, Universidade de São Paulo, pp. 1 – 66.
2. Torres, I. F. R., (1999). "Efeito da Deformação por Cortante no Cálculo de Edifícios de Andares Múltiplos com Núcleos Estruturais," Dissertação de Mestrado, Escola de Engenharia de São Carlos, Universidade de São Paulo, pp. 1 – 129.
3. Mori, D.D., (1992). "Os Núcleos Estruturais e a não Linearidade Geométrica na Análise de Estruturas Tridimensionais de Edifícios Altos," Tese de Doutorado, Escola de Engenharia de São Carlos, Universidade de São Paulo, pp. 1 – 196.
4. Alan C. Hindmarch, A.C., (1983). "ODEPACK - A systemtized Collection of Ordinary differential equation Solver," in scientific computing, R. S. Stepleman et al. (eds.) North-Holland, Amsterdam, pp. 55-64.
5. Taranath, B.S., (1968). "Torsional Behavior of Open Section Shear Wall Structures", University of Southampton.
6. La Rovere, H. L., (1994). " Comparação entre os Métodos de Análise de Paredes Estruturais com Aberturas," In: International Seminar on Structural Masonry for Developing Countries, Florianópolis, Brazil, 21-24 Aug. , Proceedings, pp. 346 - 358.
7. Bathe, K. J., Lee, N. S., Bucalem, M. L, (1990). "On the Use of Hierarchical Models in Engineering Analysis," In: Computer Methods in Applied Mechanics and Engineering, North-Holland, pp. 5-26.