



THE EFFECT OF SLIP JOINTS ON LATERAL LOAD DISTRIBUTION IN LOADBEARING MASONRY SHEAR WALL SYSTEMS

D.Sutcliffe¹ and A.W.Page²

ABSTRACT

Loadbearing masonry construction with suspended concrete floor slabs is common throughout Australia, especially for low to medium rise (3–5 storey) apartment buildings. In order to accommodate any long term differential movement (eg. thermal movement, concrete shrinkage, brick growth) it is usual Australian building practice to include a slip joint to between the underside of the concrete slabs and the top of any loadbearing masonry walls. However, as well as allowing long term relative movement slip joints must also be capable of transmitting short term transient loads as a result of earthquakes and/or wind.

Conventional shear wall analysis relies on elastic theory to determine the distribution of total lateral load to individual shear walls. The inclusion of slip joints creates an elastic–plastic response whereby the shear load distributed to each wall will be determined not by the wall’s elastic stiffness but by the capacity of the joint. As lateral load levels increase, individual walls will progressively slip as their shear (slip) capacity is reached, resulting in a redistribution of forces in the shear wall system. Traditional elastic theory is incapable of predicting the redistribution of load in the shear wall system and so may not give a true indication of the peak shear load in each wall as a result of progressive redistribution of load.

This paper presents a preliminary, conceptual analysis of the effect the inclusion of slip joints has on the distribution of shear in some typical loadbearing masonry buildings. The effect is studied using a finite element analysis of symmetrical and unsymmetrical wall layouts for an idealised loadbearing structure with and without slip joints. It is shown that the influence of the slip joint is indeed significant, and must be considered if realistic wall racking loads are to be predicted.

Key words: Loadbearing masonry, Slip joints, Shear wall response.

1. Consulting Engineer and PhD Candidate
Lindsay and Dynan Pty. Limited,
Consulting Civil, Structural and Mechanical
Engineers
NSW, Australia. 2292.
Australia
email: daniel@lindsaydynan.com.au

2. CBPI Professor and Dean
Department of Civil, Surveying and
Environmental Engineering
The University of Newcastle
NSW, Australia. 2308.
email: apage@mail.newcastle.edu.au

INTRODUCTION

Unreinforced masonry is widely used throughout Australia as a structural element in loadbearing construction. Most commonly, loadbearing masonry is used in 3 to 5 storey apartment buildings in conjunction with suspended concrete floor slabs which also act as stiff horizontal diaphragms. The typically modular nature of the buildings is used to provide sufficient lateral capacity in the two principal orthogonal directions.

It is common building practice in Australia to include some form of slip joint between the top of loadbearing masonry walls and the underside of concrete floor slabs (see Figure 1). The slip joints typically consist of one or two layers of damp-proof course membrane (usually embossed plastic or bitumen coated aluminium). The properties of these joints are of particular importance as they must be capable of performing two apparently conflicting requirements:

- transfer horizontal short term transient loads resulting from earthquake and/or wind, and
- allow long term relative movement between the concrete slab diaphragm and the wall due to differential movements (eg. thermal effects, concrete shrinkage, brick growth).

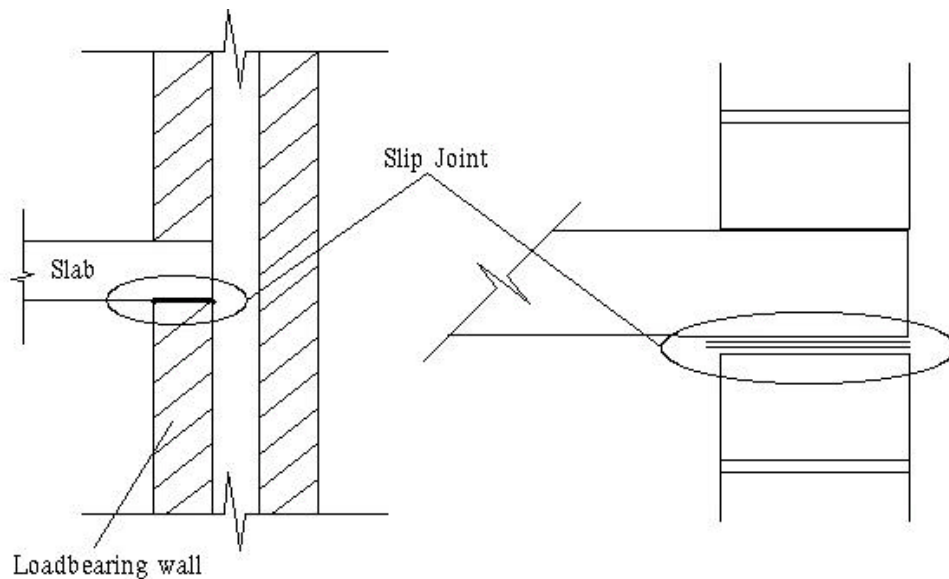

Figure 1. Typical slip joint in loadbearing masonry construction

Despite the amount of data available in the literature on the response of single joints subjected to combined compression and shear loading, little research has been carried out on the effect these joints have on the distribution of the shear force between the various walls in the total shear wall system of a loadbearing masonry building.

Conventional shear wall analysis in loadbearing masonry structures assumes an elastic response, with the total applied load being distributed to the shear walls in proportion to their elastic stiffness. However, where slip joints with an elastic–plastic response are incorporated at each floor level at every wall–slab interface, shear capacities of each wall will be controlled by the joint slip capacity (a function of the precompression and the frictional characteristics of the joint). As the applied shear load increases, individual walls will progressively slip as their shear capacity is reached. Assuming there is no redistribution of vertical load, after slip has occurred the capacity of these walls will remain constant. Further increases in horizontal load will result in a redistribution of forces to more lightly loaded walls, until at ultimate, all slip joints will have reached their shear capacity. Traditional elastic theory will not predict the redistribution of load to the shear walls, and thus not give a true indication of the ultimate shear load in each wall.

THE RESPONSE OF SLIP JOINTS SUBJECTED TO IN–PLANE SHEAR LOAD

The response of slip joint materials has been widely reported in the literature for both static, unidirectional loading, and dynamic loading conditions (eg. Chen, 1999; Page, 1994; Griffith and Page, 1998).

The failure of a typical slip joint connection subject to combined normal compression and in–plane shear loading can be expressed using a classical Mohr–Coulomb relationship as seen in Equation (1).

$$V = V_o + N \tan f \quad (1)$$

where V is the shear capacity of the joint, V_o is the inherent shear strength of the joint (ie. the shear strength of the joint under zero normal pre–compression; typically zero for slip joints), N is the normal pre–compression on the joint and f is the friction angle of the joint interfaces. If the shear load on the joint is less than the shear capacity of the joint (V in Equation (1)) the slip joint will exhibit an elastic response. Once the shear capacity of the joint has been exceeded however, the behaviour of the joint becomes plastic, with increased displacement at constant shearing force. The elastic plastic response of a typical slip joint is shown by the force–displacement curve in Figure 2.

A similar elastic–plastic response is displayed by joints under dynamic or cyclic loading conditions. Tests by Chen (1999) on the response of slip joints in small masonry specimens subject to cyclic loads show a hysteretic response with little degradation of the joints shear capacity with increased number of cycles (Figure 3).

The Australian Masonry Standard (AS3700) applies a very similar equation to (1) for the capacity of unreinforced masonry shear walls with or without a slip joint. (equation (2)).

$$V_d = V_o + V_l \quad (2)$$

where V_o is the inherent joint shear strength as defined above, and $V_l = k_v f_d A_{dw}$ with $f_d A_{dw}$ representing the average normal stress on the bed joint under consideration and k_v representing the friction coefficient of the joint (*cf.* $\tan \boldsymbol{f}$). This equation represents the actual response of the wall only if the mode of failure is shear sliding along a single bed joint plane (as is often the case for walls which contain a slip joint or damp proof course). However, for walls which exhibit a failure mode due to biaxial tension/compression characterised by a stepped diagonal crack, Equation (2) does not capture the exact nature of the wall failure and is merely an empirical relationship. For walls which fail in this manner, the choice of a suitably chosen (low) value of k_v ensures the method results in a conservative estimate of shear wall capacity.

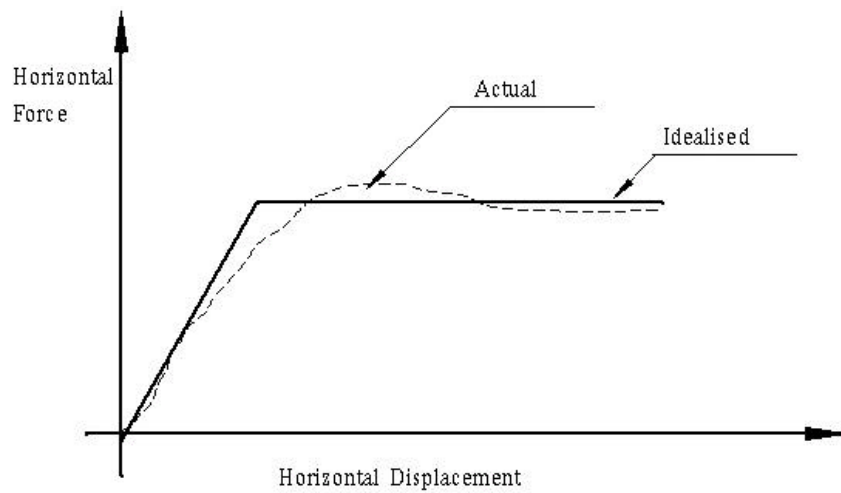

Figure 2. Elastic-plastic response of a typical slip joint

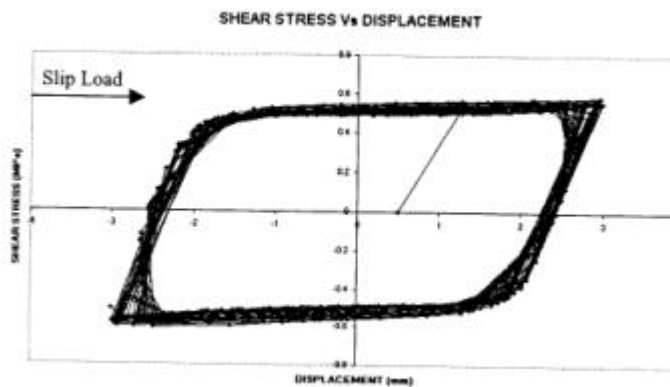

Figure 3. Typical hysteresis curve for masonry slip joint (Chen, 1999)

CONVENTIONAL SHEAR WALL ANALYSIS - ELASTIC METHOD

In conventional analysis of shear wall systems in loadbearing masonry buildings the concrete floor is assumed to act as a diaphragm with infinite in-plane stiffness. Thus the distribution of total lateral load to each individual shear wall is calculated based on the elastic stiffness of the wall. Assuming the walls deflect elastically as in Figure 4, the elastic stiffness is given by $12EI/L^3 + GA/aPL$, where L is the height of the wall, E and G are respectively the elastic modulus and shear modulus of the masonry material, A is the plan area of the masonry wall, I is the second moment of area of the wall in plan and a is the shear deformation coefficient.

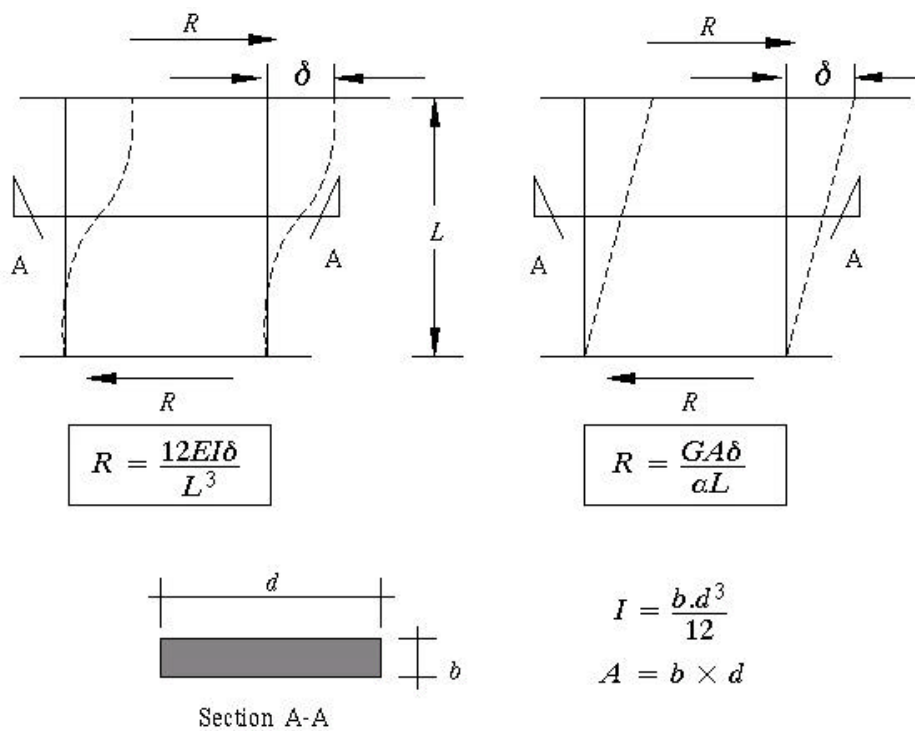

Figure 4. Elastic deflection of a masonry shear wall

In this traditional form of analysis, if the load in any single wall exceeds the capacity of the wall then the entire system is assumed to have failed. As such this method considers only the worst wall in the system, without considering possible redistribution of stresses after the failure of individual components.

THE BEHAVIOUR OF SHEAR WALL SYSTEMS INCORPORATING SLIP JOINTS

The response of a masonry shear wall system containing slip joints is considerably different to the purely elastic response discussed above. Prior to plastic sliding of the slip joint connections the distribution of total lateral load to the individual resisting elements is determined by their elastic stiffness. As the joints progressively slip, the distribution of lateral load becomes a function of both the elastic stiffness (for the walls which have not slipped) and vertical precompression on individual walls (for walls where the slip capacity has been reached). The implications of this on design procedures can best be explained by way of a simple example.

Consider the shear wall system shown below in Figure 5. If we assume that the elastic stiffness of walls 1 and 4 is twice that of walls 2 and 3, then the elastic distribution of loads becomes $P/3$ in walls 1 and 4, and $P/6$ in walls 2 and 3. Now if the capacity of all walls is equal to Q then under a traditional analysis, failure occurs when the load in any individual wall exceeds the capacity of that wall. Since the highest loads occur in walls 1 and 4, failure occurs when $P/3=Q$ or at a total lateral load of $3Q$.

Now let us consider what happens if the plastic response of the slip joints is considered. When the loads in walls 1 and 4 reach $P/3$, these walls do not 'fail', but continue to support this constant load under continued shear displacement. As the total lateral load is increased beyond $3Q$, the proportion of the total load carried by walls 2 and 3 increases until these walls too begin to slip. Thus only when all of the walls have begun to slide has the system reached its maximum capacity. In this instance the maximum capacity then is given by $P=4Q$. This response is shown diagrammatically in Figure 6.

It should be noted here that the previous example is very specific and simple, based on a symmetrical shear wall layout. The response of a non-symmetrical shear wall system, while essentially the same, is complicated by the inclusion of torsional effects, and the redistribution of shear to walls perpendicular to the principal lateral load direction. In the

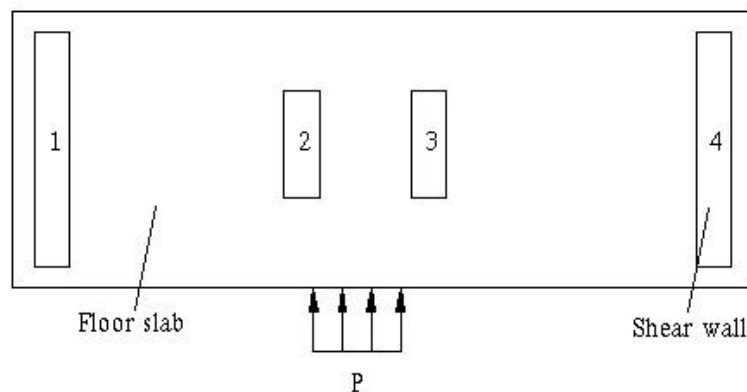

Figure 5. Simple shear wall system (plan view)

following section results of a simple finite element analysis of two typical shear wall systems (one symmetric and one non-symmetric) are presented.

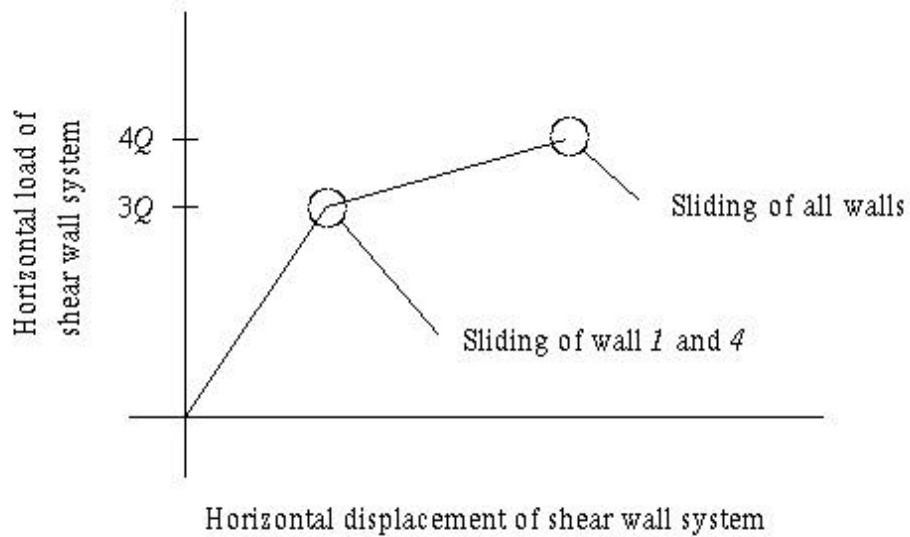

Figure 6. Simple shear wall system

FINITE ELEMENT ANALYSIS

In order to assess the response of an actual shear wall system containing slip joints, an elastic finite element analysis was carried out using STRAND7, a commercial finite element analysis software package. To simulate the presence of a slip joint, point contact elements were positioned between the plate elements used to model the concrete floor slab diaphragm and the masonry shear walls. Failure of the masonry wall itself (ie failure of the wall in biaxial tension/compression) is beyond the scope of the present research and was not considered in the simple examples presented here. Rather, failure was assumed to be confined solely to the plane of the slip joint. In this way the effect of the joint alone can be examined.

SYMMETRICAL WALL LAYOUT

The first problem to be analysed is that of the symmetrical wall layout shown in Figure 7. To study the response of each wall as well as the progressive response of the overall system, small incremental loads were applied to the system until all wall slip joints began to exhibit a plastic response.

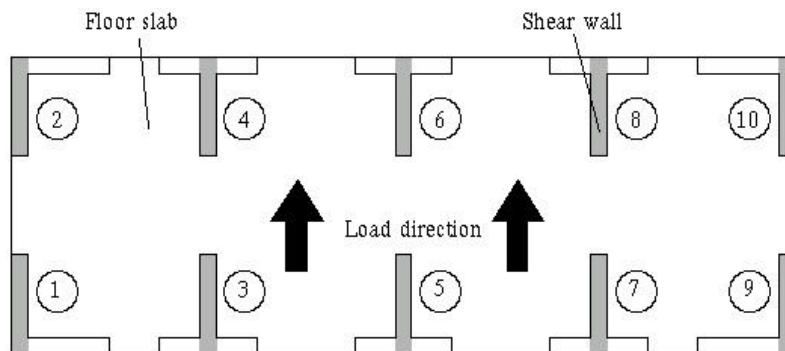

Figure 7. Symmetrical shear wall layout (plan view)

The progressive shear load in each wall is shown in Figure 8. This plot clearly shows the elastic-plastic response of the masonry walls containing a slip joint at the slab/wall interface. Further, this plot highlights the difference in collapse loads of a shear wall system predicted from elastic versus elastic-plastic assumptions. It can be seen that the collapse load predicted using elastic theory is less than 50% of the actual collapse load of the system considering the plastic response of the slip joints. The slight difference in failure loads for walls 1 and 9, and walls 2 and 10, is due to the redistribution of normal load due to overturning of the system under lateral load. A similar response was evident for the other walls, however its effect was not as pronounced.

The load displacement response of the overall system is given in Figure 9. The important thing to note from this plot is that failure of the system does not occur until all of the walls begin to slide (ie until walls 3-8 fail). Progressive failure of individual walls, while not necessarily resulting in collapse of the system, does reduce the stiffness of the system as indicated by the reduction in slope of the load-displacement diagram.

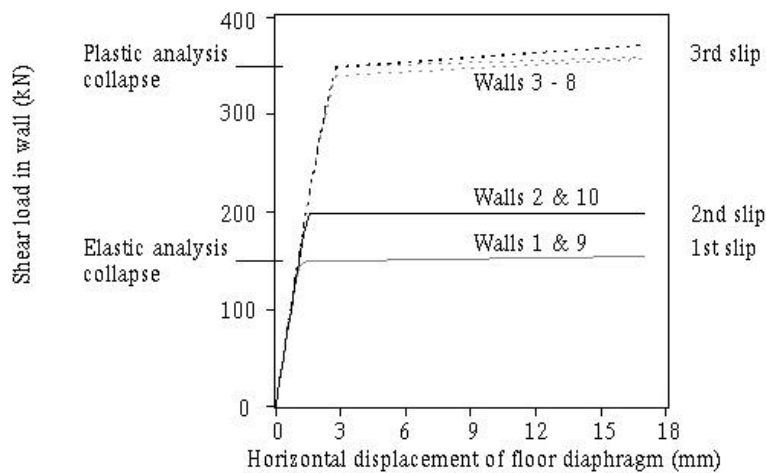

Figure 8. Response of individual walls in a symmetrical shear wall system

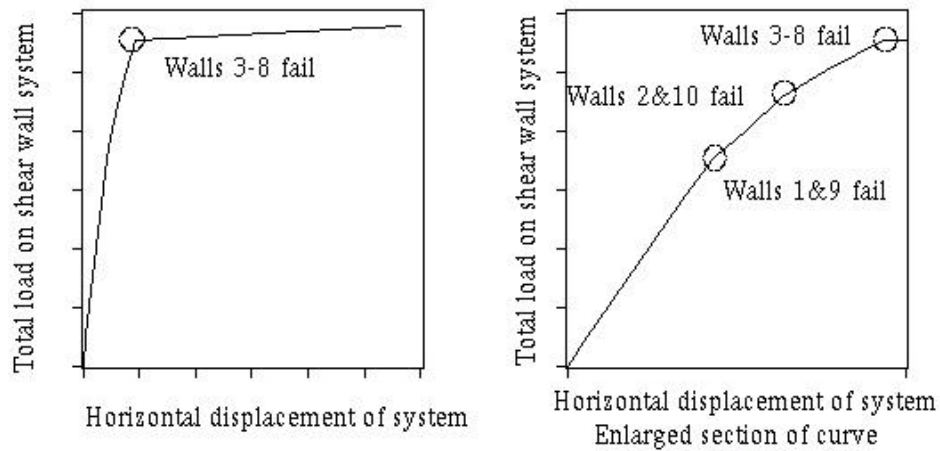

Figure 9. Global response of a symmetrical shear wall system

NON-SYMMETRICAL WALL LAYOUT

The second problem analysed is that of a non-symmetric shear wall system shown in Figure 10. As with the first example, small incremental loads were applied, and the response of each wall recorded, until all walls in the system (and as such the entire structure) failed.

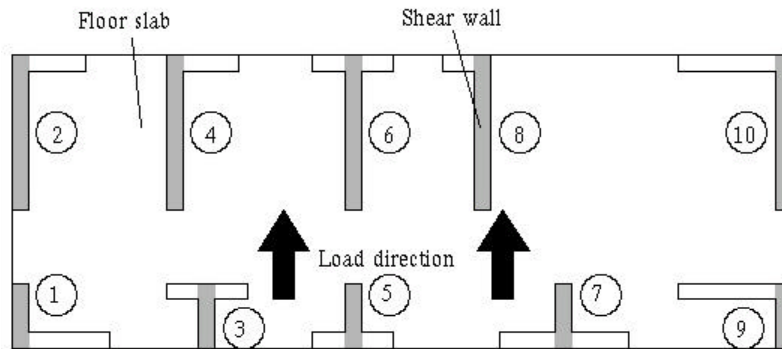

Figure 10. Non-symmetrical shear wall layout (plan view)

The response of each of the walls can be seen in Figure 11. Again the response of the walls is elastic-perfectly plastic, however the range between the failure of the first walls (walls 8 and 9) and failure of the system as a whole is significantly greater than for the symmetric wall layout.

The load–displacement response of the overall system is given in Figure 12. The results are similar to those for the symmetric wall layout case, with progressive softening of the structure as individual walls begin to slide, and a dramatic reduction in stiffness when all of the walls have failed and the floor diaphragm slides as a rigid body.

One significant point to note is the torsional effects introduced into the system when the layout of shear walls is non–symmetric. Figure 13 contains a plot of the horizontal displacements of the left and right hand edges of the floor diaphragm shown in Figure 10. These torsional effects result in in–plane forces being applied to the walls perpendicular to the load direction. Since loadbearing masonry buildings are typically modular, with numerous shear walls in both directions, the presence of torsional effects will usually not be a significant design consideration. However, for shear wall systems which are highly non–symmetric and/or have few cross walls, the torsional effect can become large and represent the critical loading condition. In these instances, rather than the floor diaphragm sliding on the top of the walls, the failure mode will be that of the floor diaphragm twisting on top of the wall system.

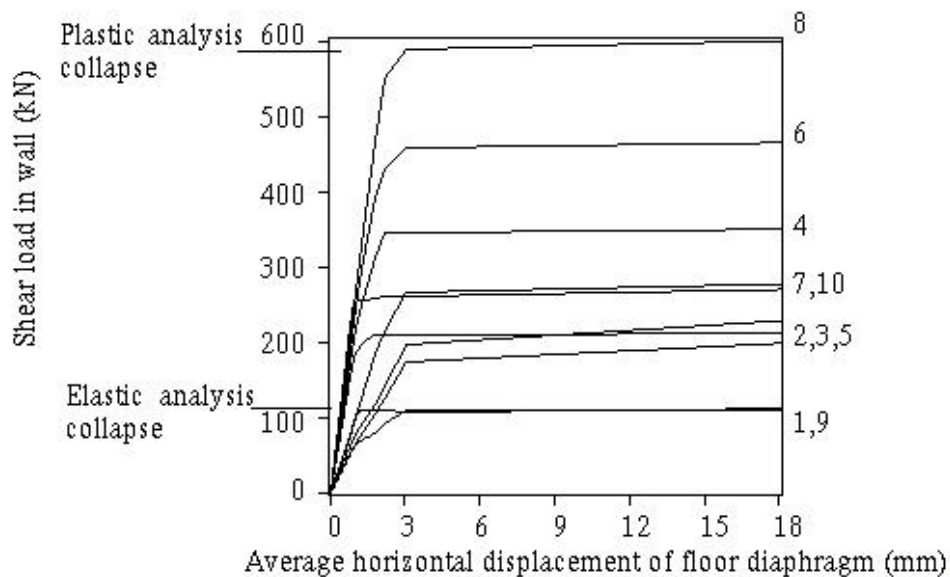

Figure 11. Response of individual shear walls in a symmetrical shear wall system

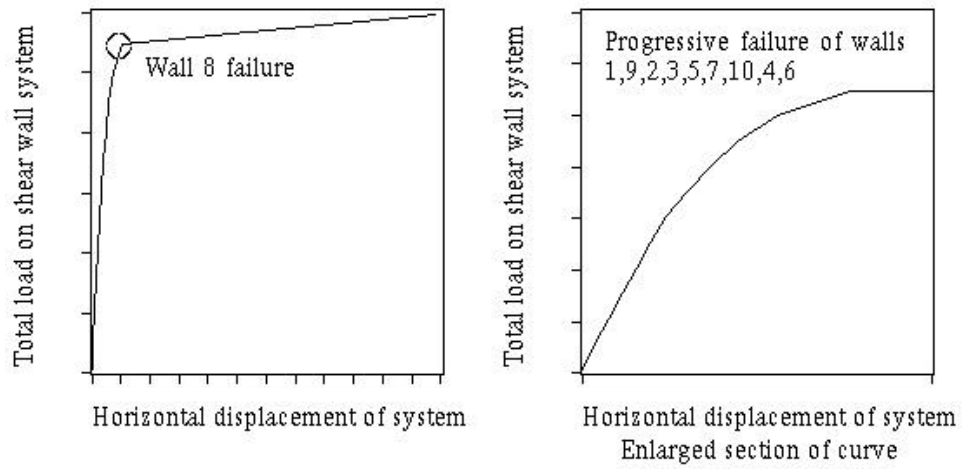

Figure 12. Global response of symmetrical shear wall system

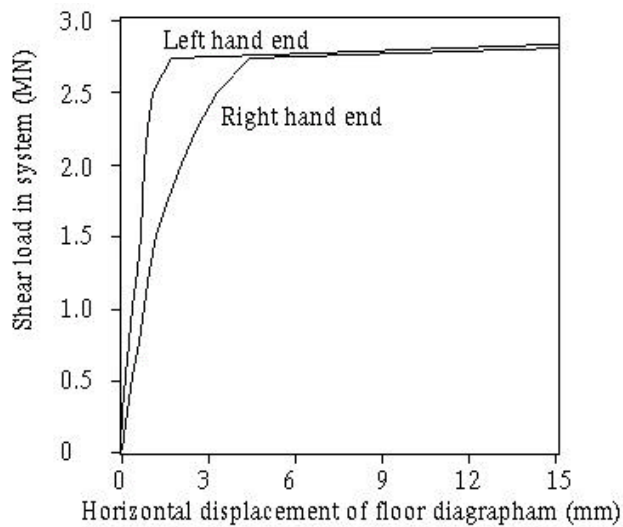

Figure 13. Torsional effects

CONCLUSIONS

The effect of the presence of slip joints on the overall response of a loadbearing masonry shear wall system has been investigated. It is shown that the presence of slip joints results in an elastic-plastic response rather than the purely elastic response which is commonly assumed in the design of typical masonry buildings.

It was shown that, for the two building layouts considered, by taking account of the load redistribution which occurs after sliding 'failure' of an individual shear wall, the overall capacity of the shear wall system is significantly greater than the capacity predicted using elastic analysis methods. It is important to note however that this may not always be the case. Highly non-symmetric shear wall systems, or systems with few cross walls may fail at loads lower than those predicted by elastic methods due to the presence of high torsional forces.

In general it can be concluded that current design methods based on elastic analysis of shear walls do not reflect the true behaviour of the shear wall system. Elastic analysis will often underestimate the capacity of the shear wall system, as failure is assumed to have occurred once the capacity of the most highly loaded wall is reached. In reality, considerable reserves of strength are inherent in the system due to the elastic-plastic response of individual walls from the influence of the slip joints. It is difficult to predict the response of a system in general, as the slip capacity of any wall is a function of both the wall geometry and level of precompression. Torsional effect will also play a role. Further work is required to clarify these effects but an elastic-plastic design approach for these types of buildings has significant potential, particularly if the slip joints are 'engineered' to have a predicted response.

REFERENCES

AS3700, Masonry structures code, Standards Association of Australia, 1998.

Chen, Q., (1999). The seismic design of connections in unreinforced masonry structures. Thesis, The University of Newcastle, Department of Civil Surveying and Environmental Engineering.

Page, A.W., (1994). A note on the shear capacity of membrane type damp-proof-courses. Department of Civil Surveying and Environmental Engineering Research Report No. 097.05.1994, The University of Newcastle, 1994.

Griffith, M.C., and Page, A.W., On the seismic capacity of typical DPC and slip joints in unreinforced masonry buildings, Australian Journal of Structural Engineering, The Institution of Engineers Australia, Vol. 1, No. 2, pp133-140, 1998.