



**Jasper, Alberta
May 31 - June 3, 1998**

**MONITORING THE HYGROTHERMAL PERFORMANCE OF A MASONRY WALL
WITH AND WITHOUT THERMAL INSULATION**

A H P Maurenbrecher, M Z Rousseau & M N A. Saïd
Institute for Research in Construction, National Research Council, Ottawa K1A 0R6

C J Shirliffe
Shirliffe & Associates, Box 9515, Station T, Ottawa K1G 3V2

ABSTRACT

A four-storey warehouse in Winnipeg, built in 1911, was converted in 1993 for use as offices and laboratories. The exterior solid masonry walls had insulation added to the inside surface to control heat flow and to improve thermal comfort. The insulation included an integrated aluminum foil facing to control vapour diffusion through the assembly.

Field monitoring of two wall sections (one insulated, the other uninsulated) was carried out in order to understand better the effect of the addition of thermal insulation and vapour barrier on the inside of solid masonry walls on the hygrothermal performance of the assemblies. Sensors were installed in the two wall sections and were monitored for several years.

The measurements determined:

- temperature differences across the wall
- effect of thermal bridging at floor level
- thermal resistance of wall components
- air pressure difference across the wall
- wetting by rain of the exterior wall
- moisture changes in the wall and surface condensation

This paper presents results from the monitoring, including a comparison of the performance of the insulated to the uninsulated wall sections.

BUILDING DESCRIPTION

The Winnipeg Customs Examining Warehouse (also known as the Inland Revenue Building) is a historic four-storey masonry building built in 1908-1911 (Fig 1). The structural components consist of a steel frame encased in concrete or masonry, reinforced concrete floors and roof deck, and masonry exterior walls. Large windows comprise about 38% of the facade. The solid masonry walls consist of one wythe of clay facing brick backed by multiple wythes of sand-lime brick (from two to seven wythes). The thickness of the walls varies from about 900 mm on the ground floor to 300 mm on the top floor. Steel columns are embedded in the masonry on three facades (Fig 2).

A very extensive renovation was completed in 1993. The ground floor now houses Customs offices while the upper three floors house the Artifact Restoration workshops and laboratories of the Canadian Parks Service. This new use of the building space required stable indoor temperatures, and, in some areas, stable humidity levels. The renovation of the building envelope consisted of insulating the inside of the masonry walls, adding a vapour barrier, replacing all windows, installing a new waterproof roofing membrane on the flat roof, and installing a forced air HVAC system and hot water radiators under the windows. Figure 3 shows the composition of the retrofitted masonry wall. Aluminum foil on the inside surface of the semi-rigid glass fibre insulation acts as the vapour barrier. All the joints between the insulation boards were taped and the top and bottom were caulked to the concrete slabs at the ceiling and floor levels. However, the authors suspect that the thick masonry in the wall would probably act as a better air barrier system than the foil, provided that the junction with the windows was sealed. On the inside of the insulation and vapour barrier, a steel stud frame was installed about 35 mm away from the insulation; that stud space was used for the installation of services. The drywall interior finish was fixed to the stud frame, and painted (Fig. 3).

PERFORMANCE ISSUES RELATED TO THERMAL UPGRADING

In terms of energy conservation, durability and convenience, adding insulation to the exterior of the wall is usually best because the masonry becomes protected from temperature and moisture fluctuations. However, in many cases the exterior appearance of the building must be maintained. The placement of thermal insulation on the inside of existing solid uninsulated masonry walls and its effect on the durability of the masonry has a history of controversy [Rousseau et al 1990]. This results in larger yearly temperature ranges in the masonry. It also reduces the drying rate of the masonry because of reduced heat flow from the interior. Concerns have also been raised over the increased risk of condensation with associated corrosion of metal components, health risks from mould growth, and spalling and cracking of the masonry due to frost and differential movements.

In order to preserve the heritage facade of the building, the building designers retrofitted on the interior of the masonry walls. A better understanding of the hygrothermal performance of the proposed retrofit approach was needed before implementing the retrofit design. Therefore, at the design stage, the risks associated with the addition of internal thermal insulation and airtightening the exterior walls were evaluated. Two and three-dimensional

computer modeling was used to predict changes in moisture, temperature gradients, thermal resistance, and the effect of thermal bridges such as embedded steel beams on the heat flow through the wall. A continuous field monitoring program to assess the hygrothermal performance of two wall sections started after the retrofit was completed. One section was insulated, and the other was left in its original uninsulated state.

INSTRUMENTATION

The monitored wall sections are located on the third floor on the north side of the building near the north-west corner (Fig 2). This location was chosen because it is exposed to prevailing wind-driven rain, receives little solar radiation, and is easily accessible from the exterior for the placement of the sensors. The indoor air pressure on the third floor was expected to be higher than the outdoor air pressure in the winter due to stack effect (any air leakage would then be towards the exterior). The location was also in an open storage area so that both wall sections were exposed to the same indoor temperature and humidity conditions. The area contained desks around the perimeter for personnel.

Sensors were installed to monitor temperature, relative humidity, moisture content, air pressure difference across the wall, and heat flux through the wall. The sensors were all connected to a data logger with battery backup. The data was automatically transferred by modem to a computer in Ottawa. Most sensors were monitored every 10 minutes. The resistance moisture sensors and the heat flux transducers were monitored every minute and a ten-minute average stored in the data logger. The pressure sensor was monitored every half-second and a ten minute average was stored in addition to the maximum, minimum and standard deviation. Figure 4 shows the location of some of the temperature and moisture sensors.

The temperature sensors were type T thermocouples except for RTD sensors located in the humidity sensors (accuracy $\pm 0.5^{\circ}\text{C}$ & 0.3°C respectively). Three sensors monitored the relative humidity of the exterior air, interior air, and the air in the cavity between the drywall and insulation (2% accuracy over the range 20-95% at 25°C). Thermocouples were placed on the wall components and within holes drilled into the masonry.

Moisture on the exterior wall surface was monitored using the following types of sensors:

- two rain gauges of different sizes to measure the amount of rain hitting the wall (similar principle to a standard rain gauge but mounted in the vertical plane on the wall). The sensitivity for the larger gauge was 0.03 mm of rain while the smaller one was 0.4 mm.
- small electrochemical cells of alternating gold and copper electrodes producing a small voltage when wet (Sereda sensor).
- Moisture pins consisted of brass pins press fitted into holes drilled into a brick (13 mm long pins spaced 10 mm apart). The electrical resistance of the brick between the pins was measured (resistance drops with increasing moisture).

Moisture within the wall was monitored using two types of resistance moisture sensors:

- the so-called "block sensors" were made up of small blocks cut from bricks taken from the building during initial investigations. Two wires were glued to opposite faces of the blocks.
- moisture pin sensors.

Two heat flux transducers (100 mm diameter polyurethane disk, 3 mm thick) monitored the heat flux through the two test wall sections. Heat flux through the calibrated disk results in a difference in temperature between its two faces; this difference is measured by a thermopile embedded within the disk. The thermal resistance of an adjoining wall component can then be calculated, provided the temperature difference across it is measured and data is collected for a long enough period. For a given component, a change in thermal resistance with time may be an indicator of a change in moisture content (drop in thermal resistance with increased moisture).

One pressure sensor measured the difference in air pressure across the test wall section (range of sensor ± 1000 Pa).

MONITORING RESULTS

Examples of the results are presented with the emphasis on the year 1994. It was a year with a higher than normal rainfall recorded at the airport (615 mm vs the normal 404 mm), as well as a colder January (-23.1°C vs the normal average of -18.3°C).

Thermal resistance

One of the important aspects of any retrofit is the increase in thermal resistance of the building envelope. This results in reduced energy usage and improved thermal comfort for the occupants.

The thermal resistance (R) of the masonry wall was calculated using the sums of temperature differences, ΔT (K), divided by the sums of heat flux, q (W/m^2), measured through the masonry wall ($R = \Delta T/q$). Hourly averages of temperature difference and heat flux were integrated over a one-month period (ASTM standards C1046 & C1155). It was estimated using cross-correlation calculations that a 72-hour time lag existed between the temperature fluctuations and the heat flux through the wall because of the thermal mass of the wall. Thermal resistance varies with temperature; therefore the average value was adjusted to a standard temperature of 24°C using the following equation:

$$RSI_{24} = RSI_{T_m} [1 - k (24 - T_m)] \quad (1)$$

T_m is the mean temperature of the masonry over the averaging period.

k is a constant = 0.002 derived from thermal conductivity measurements at two different temperatures on the sand-lime brick (Table 1).

Table 1 Thermal conductivity of the bricks

| Brick type | Density ¹ kg/m ³ | Thermal conductivity ¹ W/(m.K) | | |
|------------|---|---|----------|-----------------------|
| | | Dry 7.3°C | Dry 30°C | Wet ² 30°C |
| Clay | 1676 | 0.40 | 0.44 | 0.78 |
| Sand-lime | 1727 | 0.40 | 0.42 | 0.62 |

1. Density & thermal conductivity were determined from 10 mm thick slices cut from the brick. The test method ASTM C518-85 Steady-State Transmission Properties by Means of a Heat Flow Meter Apparatus was used with a small (30 cm by 30 cm) heat flow meter apparatus.
2. Water content of sand-lime brick 11% by weight; clay brick 16% (approx 24 hour water soak). In saturated state, apparent thermal conductivity was measured.

Figure 5 shows the thermal resistance of the masonry and the glass fibre insulation for the cold months in 1994 and, for comparison, January in the following years. The values do not include the interior and exterior surface air film coefficients. The mean RSI value for the masonry was 2.0 in the uninsulated wall and 1.2 in the insulated wall. The glass fibre insulation had an average value of 1.7.

The thermal resistance of the masonry in the insulated wall was on average 40% lower than the masonry in the uninsulated wall. The reason for such a large difference is not fully clear. There can be many explanations to account for the difference. Either the difference in thermal resistance is real or it is a measurement error. If the difference is real, it could be partially due to a higher moisture content or variation in the construction of the two wall sections. However the moisture sensors installed did not indicate high moisture levels and the modelling study predicted only slightly increased moisture levels (due to lower thermal gradient across the wall which in turn, reduces the drying potential). Variation in the construction of the wall sections include differences in the locations and geometry of the steel structural components in the wall and multiple air voids in the masonry assembly. These factors require further investigation before final conclusions can be drawn.

The thermal conductivity of dry and saturated brick samples was measured in the laboratory (Table 1). Based on these measurements, the calculated RSI value of the masonry would vary from 1.8 for dry masonry to 1.2 for saturated masonry (a reduction of 33%). The value of 1.8 derived from the laboratory measurements on the brick is less than the value of 2.0 from field measurements on the masonry in the uninsulated wall.

The thermal resistance of the 55-mm thick glass fibre insulation varied between RSI 1.6 and 1.7 which is close to the nominal design value of 1.58 at 24°C mean temperature (Fiberglas wall design guide; AF530 series). In Equation 1, the constant k was taken as 0.004 (based on laboratory measurement of a glass fibre sample of similar density, 48 kg/m³).

The total measured thermal resistance for the masonry and glass fibre insulation varied between RSI 2.8 and 3.1. Therefore the renovation of the wall resulted in an increase of the thermal resistance by 40 to 55% compared to the uninsulated wall. If the ASHRAE Handbook (1993) design conductivity of 0.7 W/(m.K) for clay brick had been assumed

(density approximately 1700 kg/m^3), the calculated RSI value for the masonry portion of the wall would have been 1.1, and together with the insulation it would add up to 2.7. This value is in agreement with the R value of the masonry and insulation in the insulated wall based on the field measurements. However for the uninsulated wall, the R value of the masonry wall as estimated with ASHRAE Handbook (1993) is not in agreement with the R value based on field measurements.

Temperature range across the masonry wall

Figure 6 shows the maximum and minimum temperatures recorded over a period of a year and a half across the insulated and uninsulated walls (at mid-height). The temperature range on the exterior face of the brick wall is nearly the same for both walls (60°C). But the temperature range is much greater on the interior face of the brick in the insulated wall than in the uninsulated wall because of the added insulation (36°C compared to 9°C).

Figure 7 shows the yearly variation of maximum and minimum monthly temperature at the exterior and interior face of the brick in both wall sections. The addition of insulation on the inside face of the masonry hardly affects the temperature on the exterior of the wall. The temperature at that location is mainly affected by the outside air temperature (solar effects are minimal because of the northerly orientation).

In the coldest part of winter, the inside face of the masonry on the insulated wall can be 25°C lower than the inside face of the uninsulated masonry. The temperature on the inside face of the uninsulated masonry hardly dropped below 15°C while the inside face of the insulated masonry dropped below freezing for several months in the winter (in January 1994 the masonry in the insulated wall did not rise above 0°C). This data indicates that adding thermal insulation on the inside face increases the risk for condensation or ice formation on the inside face of the masonry should moisture transfer occur, either by diffusion or air exfiltration.

Thermal bridges

A thermal bridge occurs at locations of high thermal conductance relative to areas of low conductance. Studs, joists, beams and floor slabs as well as window frames can act as thermal bridges. Thermal bridges result in higher heat losses, and more importantly, can result in durability-related problems such as local surface condensation, mould growth and dust marking.

Preliminary investigations of the building indicated that steel beams and columns embedded in the masonry could act as thermal bridges where they connect with concrete encased steel beams in the heated space. The concrete floor slab is also in direct contact with the exterior masonry wall thus producing a low resistance path for heat to flow around the insulation. The potential thermal bridge at the floor slab-wall intersection was selected for further investigation. Modelling of the temperature profile was used at the design stage to support the selection of a retrofit technique while monitoring was used in the operational stage to follow-up on actual performance. For the monitoring, thermocouples were located in both the insulated and uninsulated wall sections on the surface of the floor (Fig 4, T10, T47, and T48).

Insulated wall

Figure 8 shows that the temperature in January at mid-height on the inside face of the drywall at mid-span between metal studs (T43) is quite steady at 21°C and is not affected by the fluctuations in the cold exterior surface temperature of the wall.

At the floor slab directly underneath the drywall (T47), the temperature fluctuates slightly between 10 and 12°C, that is 9 to 11°C lower than at mid-height (T43). The concrete slab is directly connected to the cold masonry and this increases the heat flow through the slab, resulting in a significant drop in temperature at the slab perimeter. The floor temperature may be low enough to cause discomfort if people were next to the wall. Standards about thermal comfort (ANSI/ASHRAE 1992) indicate that 95% of the people require a minimum temperature of 13-15°C near the floor for foot/ankle comfort.

At the junction of the floor and the masonry in the wall (T48), the temperature fluctuates between 0 and 5°C; this is an 8°C temperature drop relative to the floor/drywall junction location (T47). T48 thermocouple is located on the cold side of the insulation, and this can explain such temperature drop. However that location still benefits from some significant heat flow from the slab: it is significantly warmer (by 10°C) than the masonry at mid-height (T41). The floor slab, acting as a thermal bridge, warms up the masonry at floor level. The warming effect of the floor slab gets dispersed into the large mass of masonry as indicated by similarities between the temperature at the outside face of the masonry at floor level and the temperature at mid-height of the inside face of the masonry wall. Because that thermal bridge tends to raise the temperature of the adjoining masonry, it does not have a negative impact on the condensation potential on the wall; however it reduces its energy-efficiency.

Condensation on inside surfaces is also a possibility but generally, during the winter, indoor humidity levels were low (Fig 9). For 23°C and 30% RH the surface temperature should be above 4°C to prevent condensation. The indoor relative humidity would have to be above 40% before condensation occurred at the wall/floor interface in the winter. Relative humidities of this magnitude would be difficult to attain in winter because the large surface area of ordinary double glazing in the building would act as condensors.

Uninsulated wall

Figure 8 shows that the temperature at mid-height on the inside face of the masonry (T6) is around 16°C to 17°C. This is about 5°C lower than the temperature of the inside face of the drywall of the insulated wall section. In terms of thermal comfort, the cooler uninsulated masonry wall surface may cause some thermal discomfort to nearby occupants because of radiative heat loss from their body towards the cooler wall surface. In terms of condensation potential, the uninsulated wall cannot sustain as high an indoor humidity level as the insulated wall section. However its surface condensation potential in the central part of the wall is low: it could sustain up to 60 % RH without condensation. Condensation would first occur at the floor/wall interface because the temperature is lower at that location.

At the wall/floor interface, the temperature (T10) ranges from 7°C to 12°C. This large difference (up to 9°C) from the mid-height location (T6) would not be expected in a completely uninsulated wall system but in this building, only a small wall section has been

left uninsulated for research purposes. Indeed the wall on the second floor as well as a small section of its ceiling have been insulated (Fig. 3). Minimal heat flow from adjacent materials was available to raise the temperature of the masonry at the floor level of the monitored uninsulated wall section. If the wall underneath the uninsulated test section was not insulated (like in a fully uninsulated building), the interior face of the wall/floor junction would be at a higher temperature than what was measured. Based on the temperature measurements, condensation would occur at the wall/floor interface when humidity level indoors exceeds 35 % RH.

Moisture

Moisture in the wall materials can come from many sources: rain and snow on the exterior, and on the interior, condensation of indoor water vapour and moisture during renovation (e.g. moisture stored in building materials).

Moisture on and in the walls was monitored by a variety of sensors. The most reliable sensors appeared to be the Sereda sensors and the moisture pin sensors (press fitted into holes drilled into the surface of the masonry). The block sensors, compared to moisture pins and Sereda sensors, were insensitive and only gave a reading when high levels of moisture were present. In more recent monitoring projects, the electrical connection between the wires and the blocks has been improved [Saïd et al, 1997]. The rain gauges meant to measure driving rain against the wall did not work well.

Driving rain

Wetting of the exterior face of the masonry often occurred during rain (Fig 10). Wetting was dependent on the wind direction. The heaviest daily rainfall recorded at the airport on July 3, 1994 hardly affected the wall sections (the wind was SSE; the rain may also have been less severe in central Winnipeg). This indicates that a small weather station installed at the monitoring site would provide a more accurate representation of the actual weather exposure of the building than the airport meteorological weather station. In 1994, the longest periods of wetting for the monitored wall sections occurred in October/November while the highest moisture level occurred during a rainstorm in July.

Condensation

Condensation was only detected on the inner surface of a window during the winter, and at mid-height on the interior surface of the uninsulated masonry wall. In summer months (June to September) moisture was registered as well: this occurred when the indoor humidity reached over 60% (Fig 9). The wall temperature was steady at 21°C to 22°C, similar to the indoor air temperature. The high daily average indoor humidity levels between May and October 1994 suggest that the HVAC system did not control the indoor humidity levels. The main source of moisture is probably from outdoor ventilation air.

During winter months, the indoor air temperature was about 21°C. The relative humidity was as low as could be detected (minimum reading for sensor 15%) except at the very end of the year when it jumped briefly to 40% and then settled down to an average of 30% the following January. In the following Januarys (1996-98) the average humidity ranged from 20 to 30%. For 16% RH and 21°C, the dew point temperature is -4°C and for 30%

humidity, the dew point temperature is 3°C. Condensation on interior surfaces is then unlikely except on the windows.

The temperature of the masonry wall surface behind the insulation dropped well below the dew point especially during January 1994. In these conditions, if indoor air gets past the aluminum foil on the insulation, moisture could condense on the masonry surface. No condensate was detected by the sensor located on the masonry surface at mid-height of the wall. The moisture pins at floor level indicated a low level of moisture but this was caused by other factors.

Construction-related moisture

During the renovations, all the windows were taken out and work was also done on the roof and parapet. With little temporary protection from the weather, rain entered the building. During this time insulation was being attached to the walls. Water was observed to be trapped behind the insulation; drying could only occur towards the exterior. Severe efflorescence near the top of the outside face of the masonry wall was observed. The efflorescence was later removed and has not returned except for a few isolated patches.

During the installation of the instrumentation in the insulated wall section, it was observed that the base of the wall was damp. Moisture pins inserted into this part of the wall confirmed the wetness; the pins have kept measuring changes in moisture throughout the monitoring period. The temperature of this part of the wall did not drop below freezing because of the warming effect of the concrete slab. With one exception, the level of moisture measured was very low, the maximum occurring over the warmer months of the year and dropping to almost zero during the colder months. The one notable exception occurred early in the monitoring (Fig 11, R34 and R22). This area of wall became completely wet, with even a ceramic block sensor located on the floor registering water. The block and the masonry around the moisture pins probably had very high moisture levels. The source of the water is not known (it may have been caused by a leak from the floor above; the ceramic block registered the moisture increase before the sensor in the wall; it occurred around midnight of June 16/17th 1993). The moisture level in the wall took several months to return to lower levels. There may be a possibility for mould growth at that location.

Air pressure difference across the wall

During the months of January, February and December of 1994 the outdoor air pressure was almost always higher than the indoor air pressure (negative pressure differential across the wall). The higher outdoor air pressure during the winter led to air infiltration at any openings in the wall. Therefore there was little potential for condensation within the wall from indoor air in winter. The dominating negative pressure across the third storey walls was induced by the independent ventilation system on the fourth floor (there are also many exhaust fans on that floor; one operates continuously). This counteracted the positive pressure normally expected near the top of buildings due to stack effect in the winter.

During the rest of the year the indoor air pressure tended to be higher when the ventilation system was switched on during the day (Figure 12 shows July & December). The HVAC

supply fan for the first three storeys of the building normally operates during working hours only. Then there can be a positive pressure across the wall (see July).

SUMMARY

The renovation of the wall resulted in an increase of the thermal resistance of the wall by 40 to 55%. The mean RSI value of 2.0 for the masonry in the uninsulated wall was much higher than the 1.2 for the masonry in the insulated wall. The reason for this large difference is not fully understood. The measured RSI value for the masonry in the uninsulated wall was also much higher than would commonly be assumed in modern design handbooks (ASHRAE 1993).

The addition of insulation on the inside face of the masonry hardly affected the temperature of the exterior face of the wall. The temperature at that location is mainly affected by the outside air temperature. However this is different for the inside face of the masonry. In the coldest part of winter, the inside face of the masonry on the insulated wall was measured to be as much as 25°C lower than the inside face of the uninsulated masonry. The temperature on the inside face of the uninsulated masonry hardly dropped below 15°C while the inside face of the insulated masonry drops below freezing for several months in the winter.

Moisture levels in the monitored wall sections do not seem to be a problem. Only at one location, at the intersection of the masonry and the floor in the insulated wall, was a continuous low level of moisture measured. This moisture was present from the start of monitoring. Mould growth could be a possibility there.

CONCLUSIONS

The thermal resistance of thick solid masonry walls is not negligible. In this building, the RSI value of the solid masonry wall (660 mm thick) was equivalent to the RSI value of the 55-mm glass fibre insulation installed.

Adding thermal insulation on the inside of masonry significantly affects the temperature regime of the masonry, mainly in cold weather conditions. The inside face of the masonry becomes significantly colder than it used to be when it was uninsulated.

The pressure difference across the wall sections monitored tended to be negative most of the time because of the ventilation systems used in the building. Outdoor air will infiltrate at locations of leakage paths in the wall.

Monitoring is useful for assessing the performance of as-built building envelope. Here are a few lessons learned during this monitoring.

- Buildings must be examined globally, taking into account the environment around the wall, connecting building elements, and the heating & ventilation system.
- Important sensors should be duplicated, and sensors should be easily accessible where possible (the rain gauges on the exterior of this building could only be accessed by crane).

- Data analysis must be done promptly, preferably by automated software in order to check for unusual occurrences such as the sudden wetting of the bottom of the masonry in the insulated wall. There should also be regular communication with the building manager.
- A small weather station should be installed at the monitoring site because airport weather data does not reflect accurately the conditions present at the site. This would include a rain gauge and an anemometer.

ACKNOWLEDGEMENTS

The authors would like to acknowledge the assistance of National Testing Laboratories in Winnipeg with the installation of the instrumentation and the opportunity of working on the building, Public Works Canada in Winnipeg for allowing us to monitor, Brendan Madden (building engineer), Jeff Marans (former Technical Officer at NRC in charge of installation and monitoring), and the many summer students who helped with the analysis of the data.

REFERENCES

- ASHRAE Handbook: Fundamentals. 1993. American Society of Heating, Refrigerating and Air-Conditioning Engineers, Inc. Atlanta, USA.
- ANSI/ASHRAE Standard 55-1992. Thermal environmental conditions for human occupancy. American Society of Heating, Refrigerating and Air-Conditioning Engineers, Inc. Atlanta, USA.
- ASTM standard C1046-90. Practice for in-situ measurement of heat flux and temperature on building envelope components. American Society for Testing and Materials. West Conshohocken, PA, USA.
- ASTM standard C1155-90. Practice for determining thermal resistance of building envelope components from in-situ data. American Society for Testing and Materials. West Conshohocken, PA, USA.
- Rousseau M Z and Maurenbrecher A H P. 1990. Rehab of solid masonry walls: the debate on the control of heat, air and moisture flows. Construction Canada, Vol 32, No 5, Sept, p 15-20.
- Saïd M N A, Brown W C, Shirliffe C J & Maurenbrecher A H P. 1997. Monitoring of the building envelope of a heritage house – a case study. Proceedings 7th Conference on Building Science and Technology. Toronto. p 243-260.

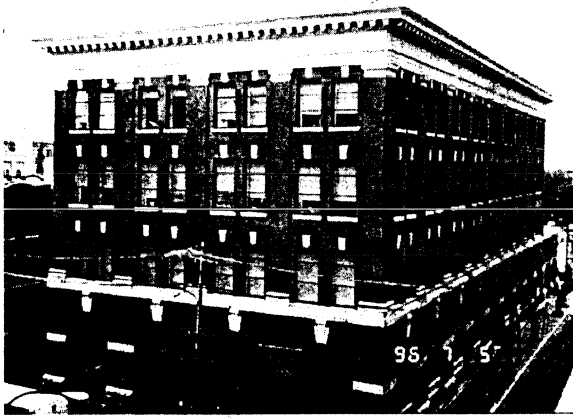

Figure 1 The Customs Examining Warehouse (view from SW)

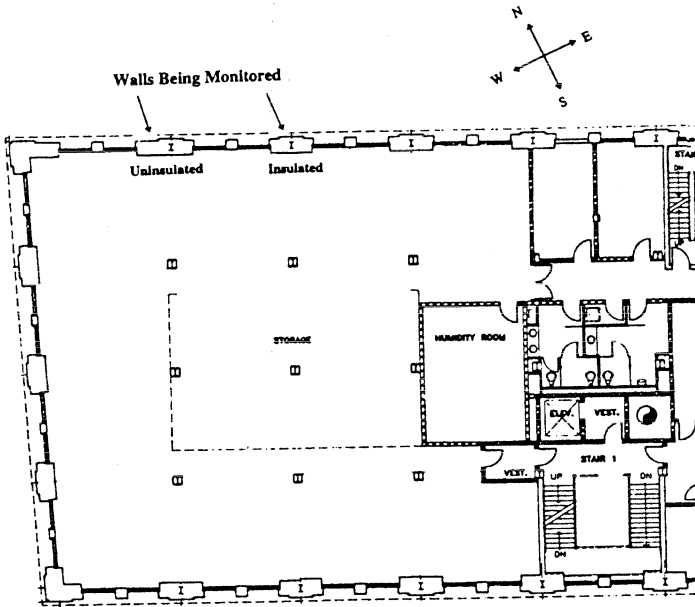

Figure 2 Plan of west end of building (3rd floor)

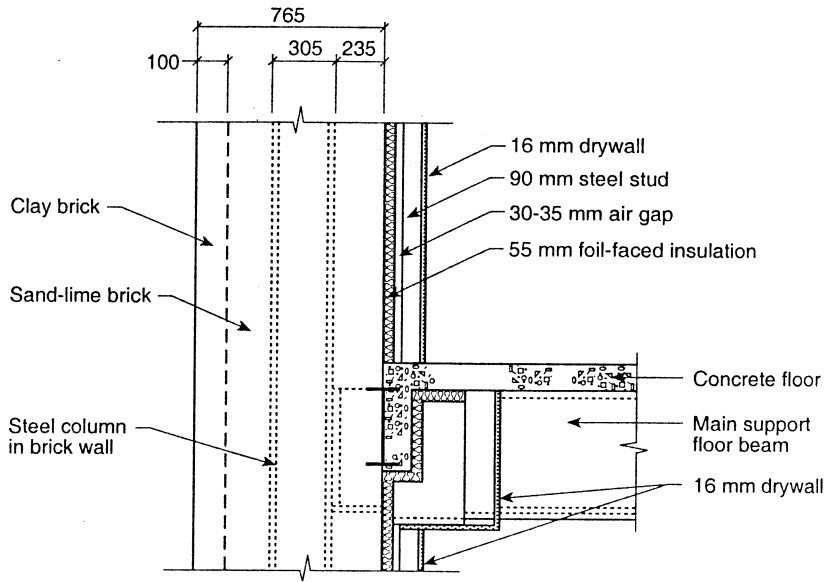

Figure 3 Renovated wall composition

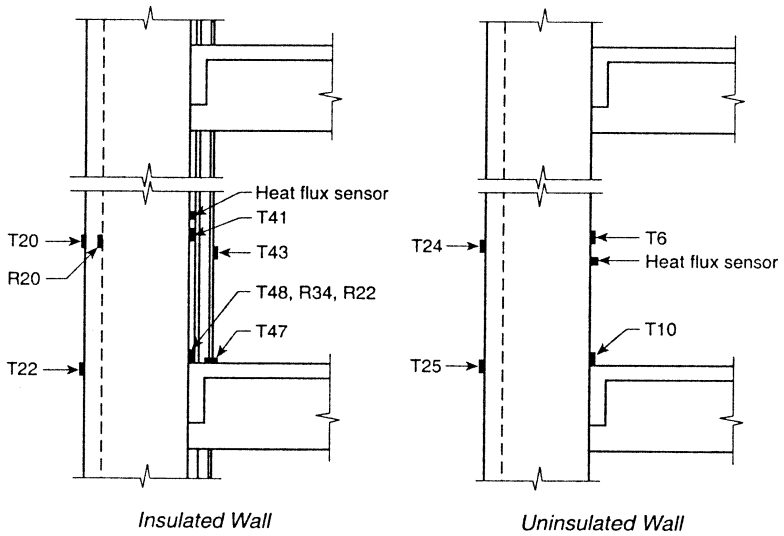

Figure 4 Location of thermocouples (T) and moisture sensors (R)

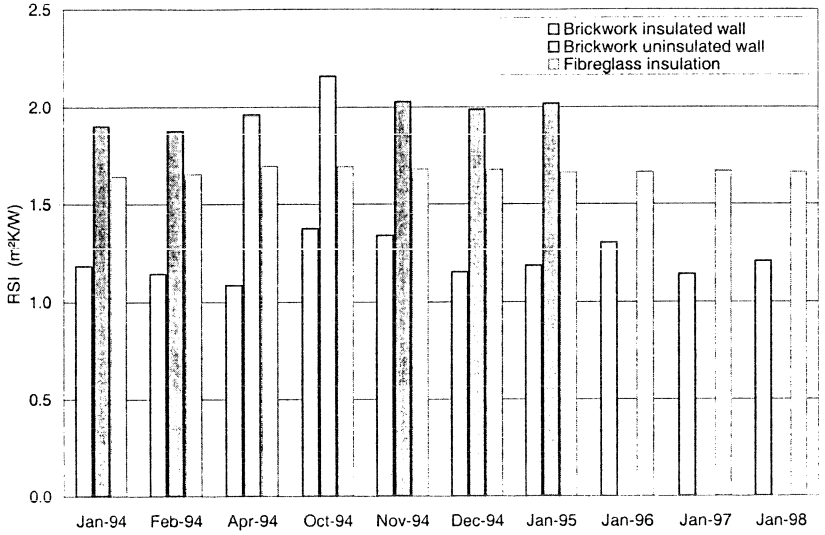

Figure 5 Variation in thermal resistance of the masonry and glass fibre insulation
Heat flux sensor removed from uninsulated wall in March 1995; $R = 5.68$ RSI

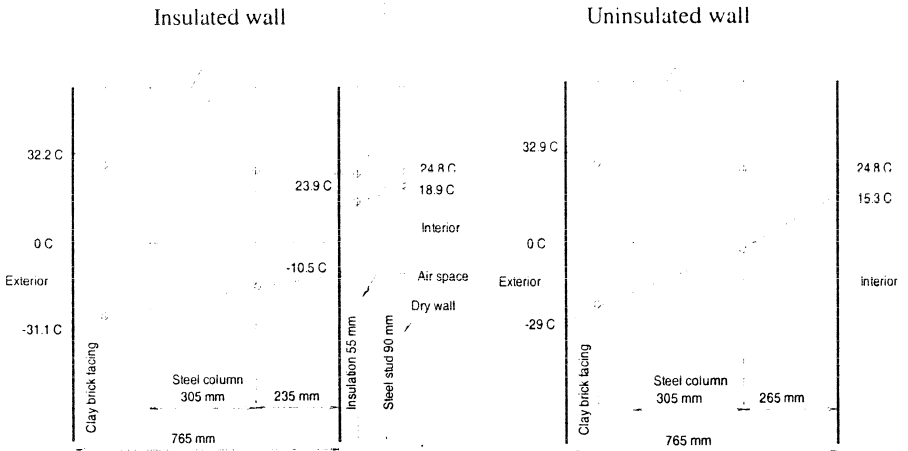

Figure 6 Maximum and minimum temperatures across the walls at mid-height in 1994
The maximum and minimum indoor air temperatures were 24.6 & 19.9°C
The maximum and minimum outdoor temperatures were 29.8 & -29.8°C

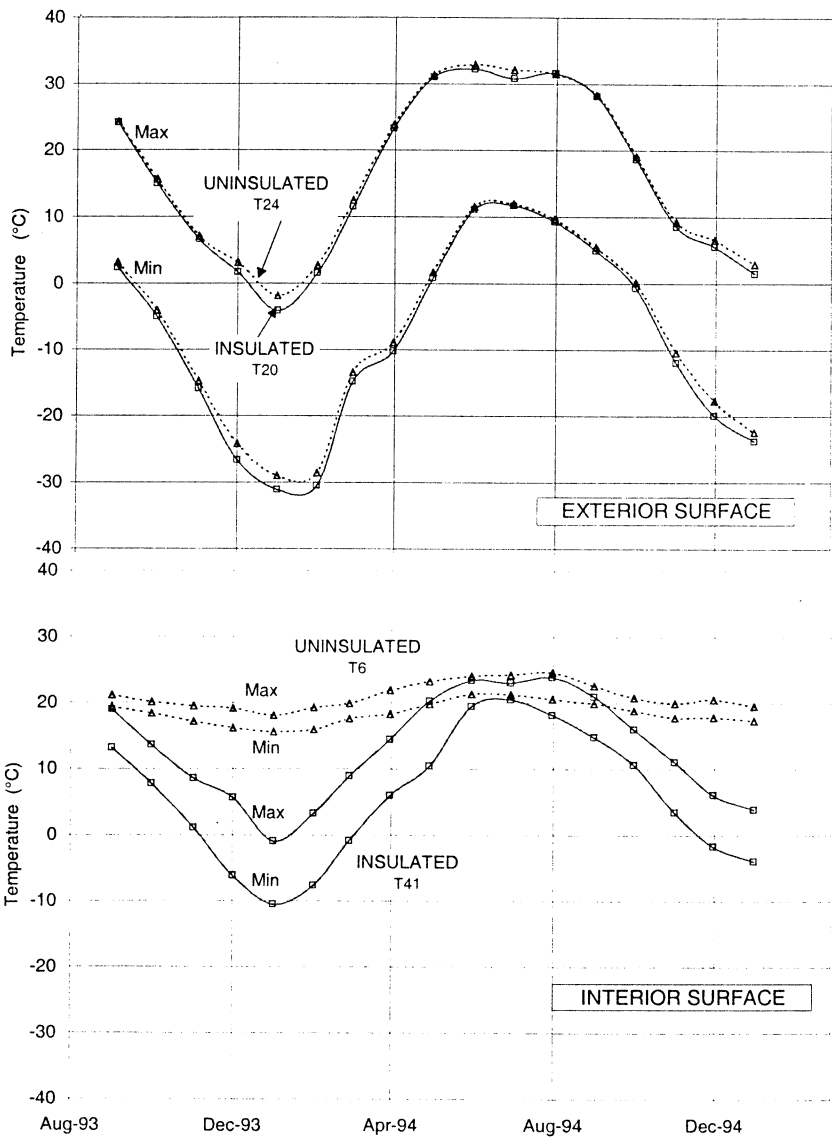

Figure 7 Monthly maximum and minimum temperatures on the exterior and interior masonry surfaces of the insulated and uninsulated walls (at mid-height)

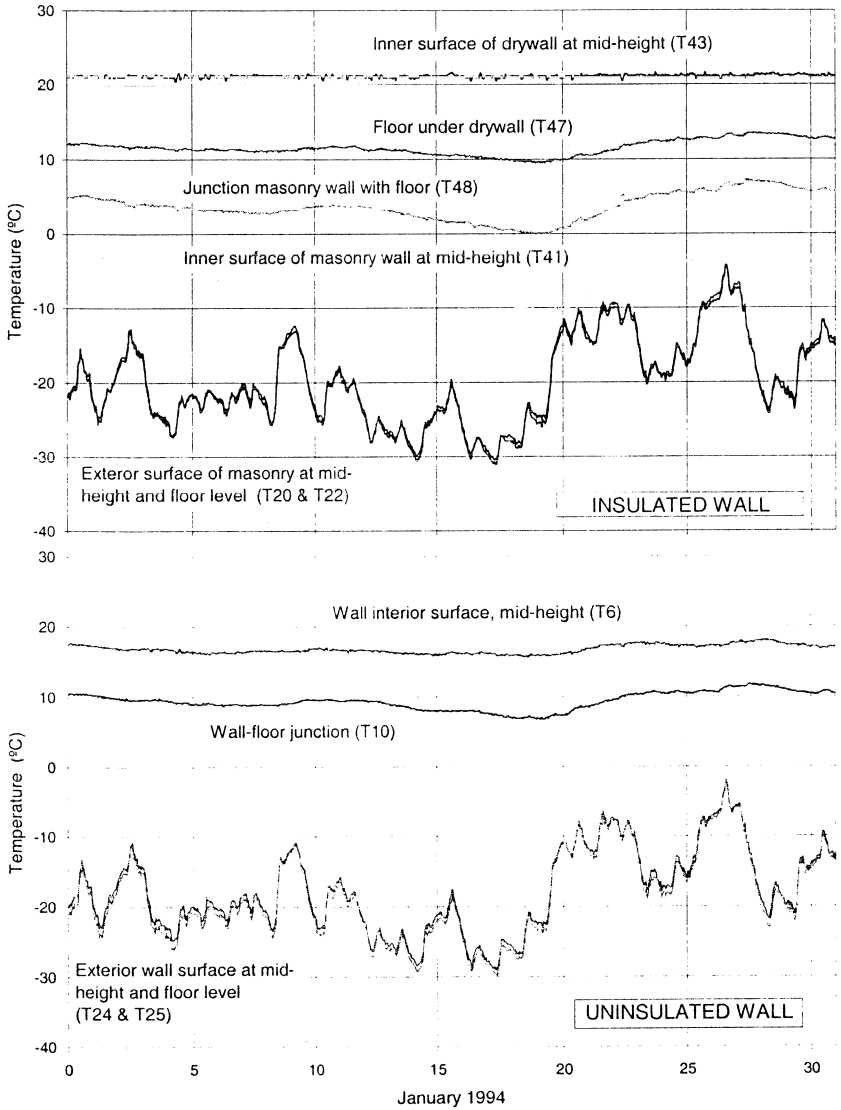

Figure 8 Temperature variation at floor and mid-height of walls in January

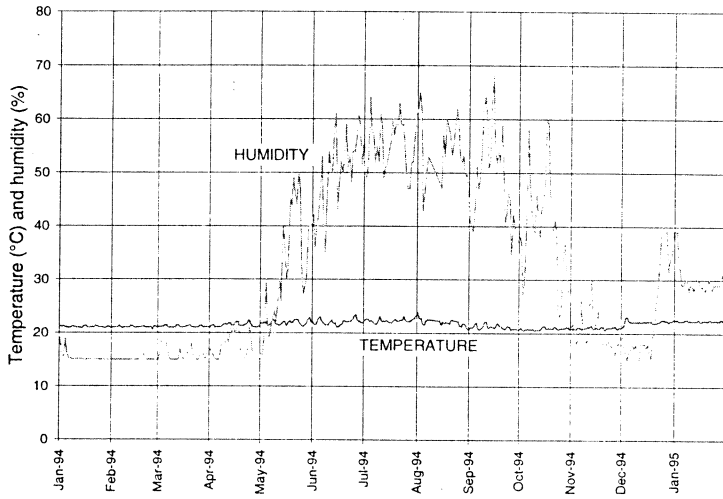

Figure 9 Average daily indoor air temperature and humidity
(Minimum reading on humidity sensor 15%)

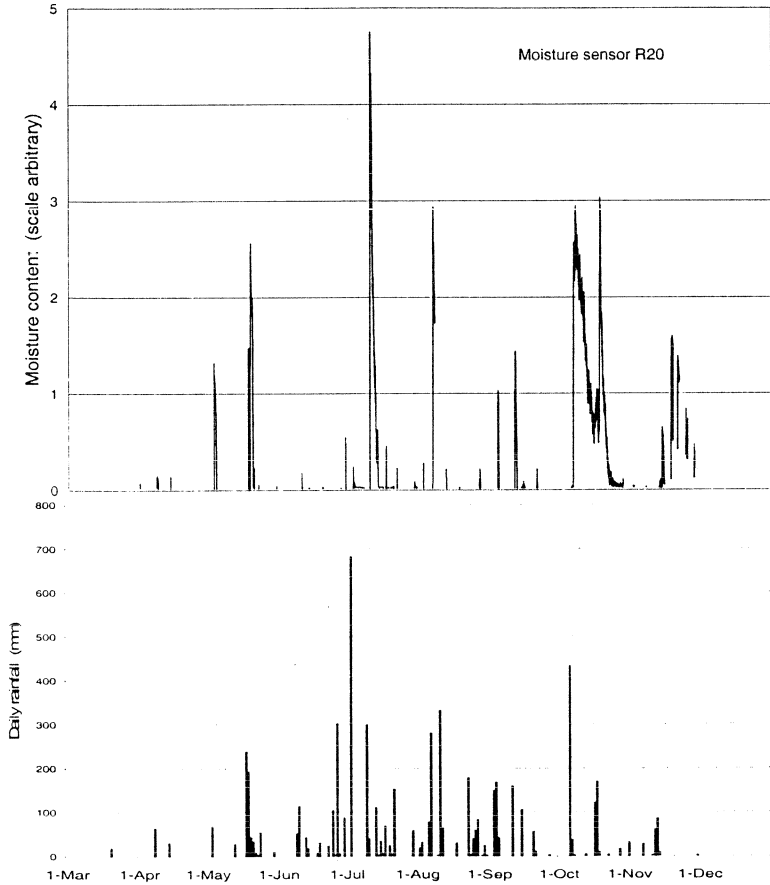

Figure 10 Wetting of exterior face of the masonry in the insulated wall in 1994
 Daily rainfall measured at Winnipeg airport. Moisture measured with two pins fitted in holes drilled 10 mm apart in a brick; plot shows half hour averages of one minute readings. No data recorded between 8-13 Aug when the second large daily rainfall in August occurred.

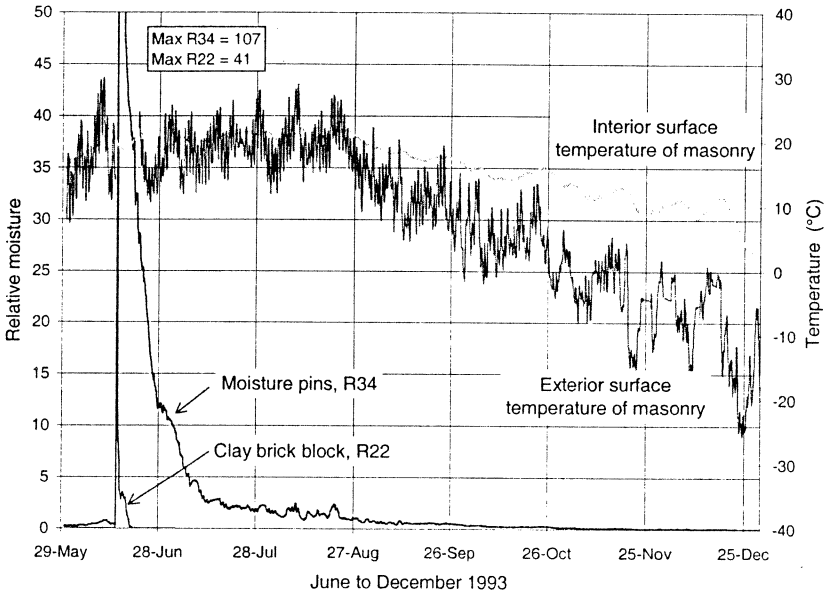

Figure 11 Moisture at the bottom of the inside face of the masonry of the insulated wall

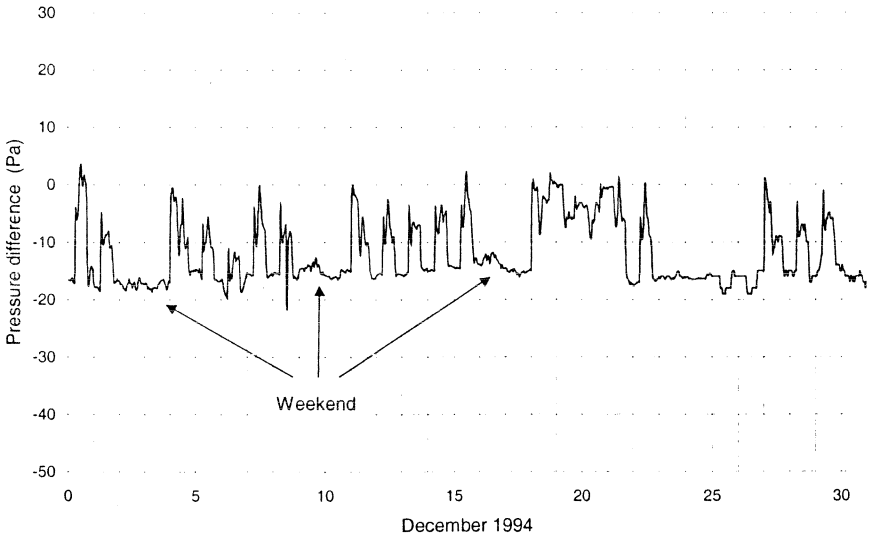
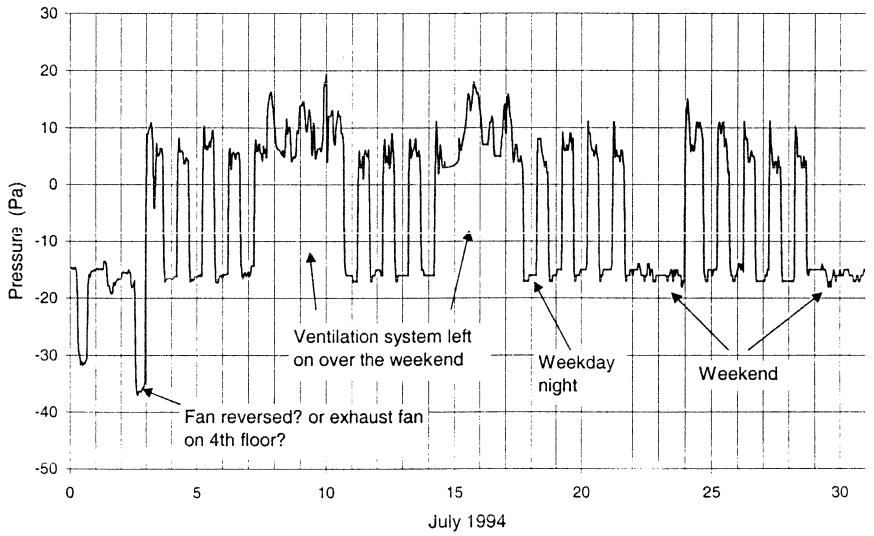

Figure 12 Air pressure difference across wall in July & December (positive pressure indicates air pressure is higher inside than outside)