



13TH CANADIAN MASONRY SYMPOSIUM
HALIFAX, CANADA
JUNE 4TH – JUNE 7TH 2017



**SLENDER UNREINFORCED MASONRY MEMBERS UNDER AXIAL LOAD AND
BIAXIAL BENDING**

Förster, Valentin¹ and Graubner, Carl-Alexander²

ABSTRACT

Unreinforced masonry members have to resist vertical loads and bending moments about the weak axis due to rotation of adjacent slabs. If the compression member is part of the bracing system, additional bending moments about the strong axis exist. Thus, the compression member is loaded with a vertical normal force which is eccentric in two ways (out-of-plane and in-plane direction). If the slenderness of the compression member is small, the compression member will fail due to crushing. If the slenderness in one direction is high, the member will fail due to buckling. This research deals with the load carrying capacity of biaxially eccentrically compressed unreinforced masonry walls and columns with linear and non-linear material behaviour. For linear-elastic material, the principles of an analytical model, which considers the geometrical non-linearity and the effect of cracking, is presented. The deflections of the wall can be determined with the derivation of moment-curvature relationships. Thereby, the analytical analysis of compression members considering the effects of 2nd order theory is possible. For a non-linear stress-strain relationship and a limited flexural tensile strength, the evaluation of the load carrying capacity of rectangular cross sections under biaxial bending is complex and has to be performed numerically. In addition to the results of the analytical model, results of numeric calculations are also shown for various eccentricities in both directions.

KEYWORDS: *biaxial bending, buckling, moment-curvature-relation, non-linear, slender, unreinforced masonry*

INTRODUCTION

Unreinforced masonry compression members like walls or columns have to carry normal compression forces and bending moments. Due to bending moments about the weak and strong axis, the compression members are loaded with a normal force which is eccentric in two directions (biaxial), see cross section in Figure 1 (left). The dimensions of the cross section are

¹ Research Assistant, Institute of Concrete and Masonry Structures, Technische Universität Darmstadt, Franziska-Braun-Straße 3, 64287 Darmstadt, Germany, foerster@massivbau.tu-darmstadt.de

² Professor, Institute of Concrete and Masonry Structures, Technische Universität Darmstadt, Franziska-Braun-Straße 3, 64287 Darmstadt, Germany, graubner@massivbau.tu-darmstadt.de

described by the thickness t and the width b . The values e_y and e_z are the eccentricities of the normal force N in each direction.

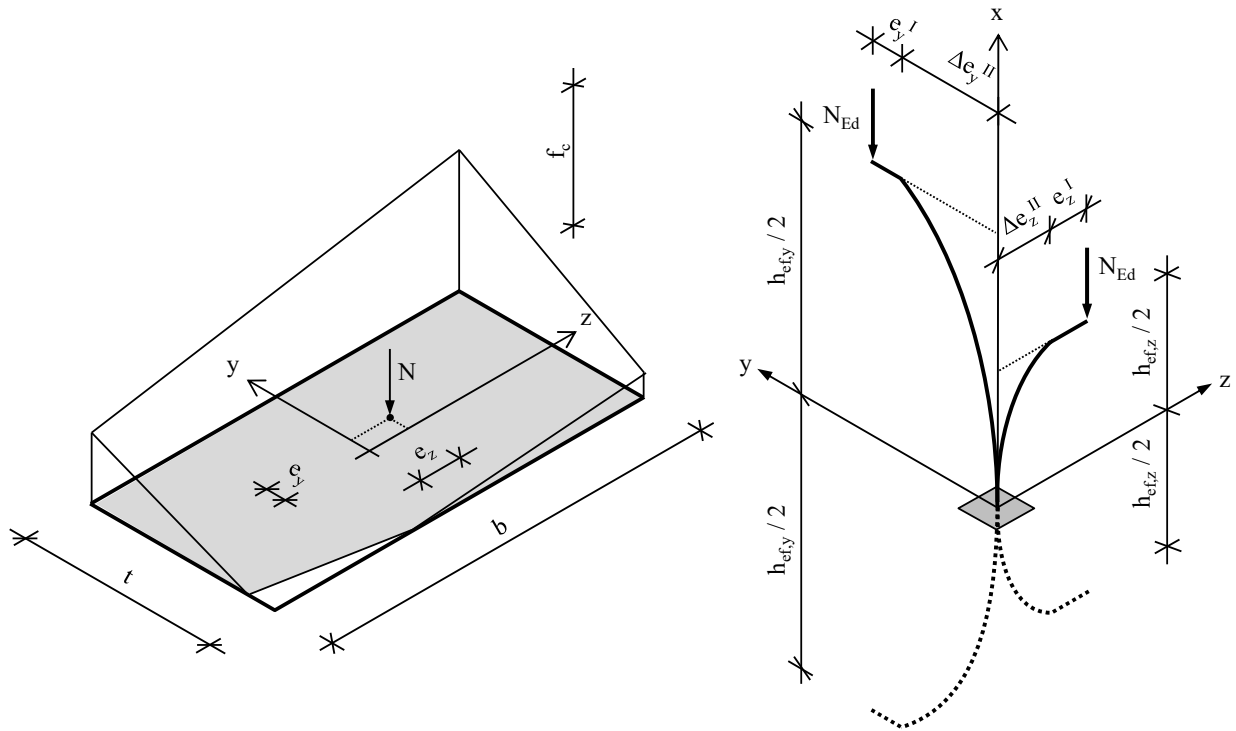

Figure 1: Stress distribution for the cracked cross section with biaxial eccentric normal force (left) and system of the compression member (right) [1]

Due to different geometrical dimensions and different supporting conditions, a different buckling length in each direction exist ($h_{ef,y}$ and $h_{ef,z}$). The general system with two different buckling lengths is shown in Figure 1 (right).

To derive the load carrying capacity of short and slender compression members regarding the non-linear behavior of unreinforced concrete and masonry, an extensive analytical and numerical model is presented in [1]. This paper shows an excerpt of that study.

BASICS

In consequence of the low flexural tensile strength of masonry, the cross section can crack if one or both load eccentricities are too large. For cross sections with linear-elastic material without flexural tensile strength, there are five different possible shapes of the compressed area which lead to five possible cases (A to E; Figure 2) for the analysis. Depending on the eccentricities, the cross section may remain uncracked (A) or may be cracked (B to E). If the cross section is cracked, the compressed area will be pentagonal, foursquare or triangular. Therefore, it is always necessary to differentiate between the described cases. This applies to the load carrying capacity of the cross sections, the moment-curvature relationship and also to the load carrying capacity of the compression member. In the following, only the principles of the analytical model and the

load carrying capacity of uncracked compression members (A) are presented. The solutions for cases B to D are very complex. The full model is presented in [1].

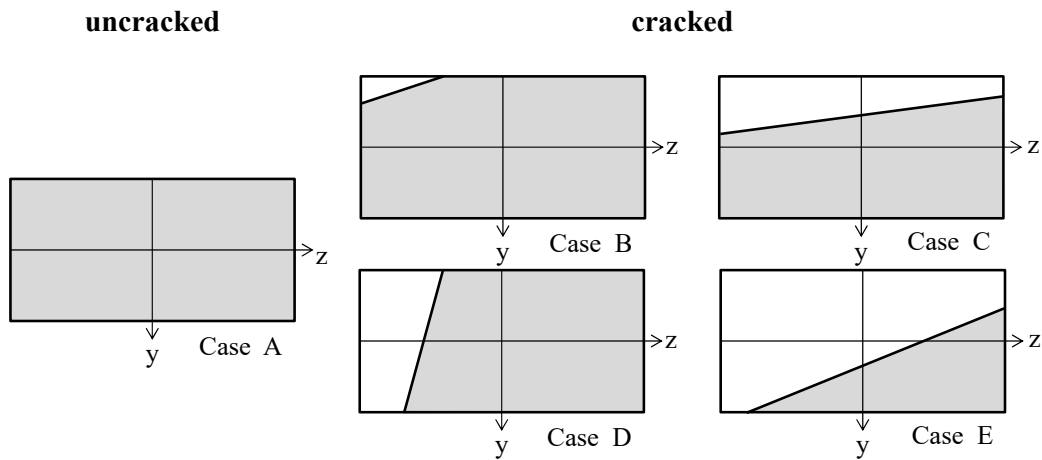

Figure 2: Compressed areas for the different cases [1]

Figure 3 shows the normal force and bending moments about each axis for the load effects and for the resistance of the cross section. For biaxial bending, the bending moment about one axis reduces the bending resistance about the other axis. According to 1st order theory, no additional deflections are considered and the bending moments are proportional to the eccentric normal forces. Considering 2nd order theory, the bending moments increase non-linearly and the bending moments depend on the slenderness of the compression member. For short compression members, 2nd order theory can be neglected, but for slender members, 2nd order theory has to be considered.

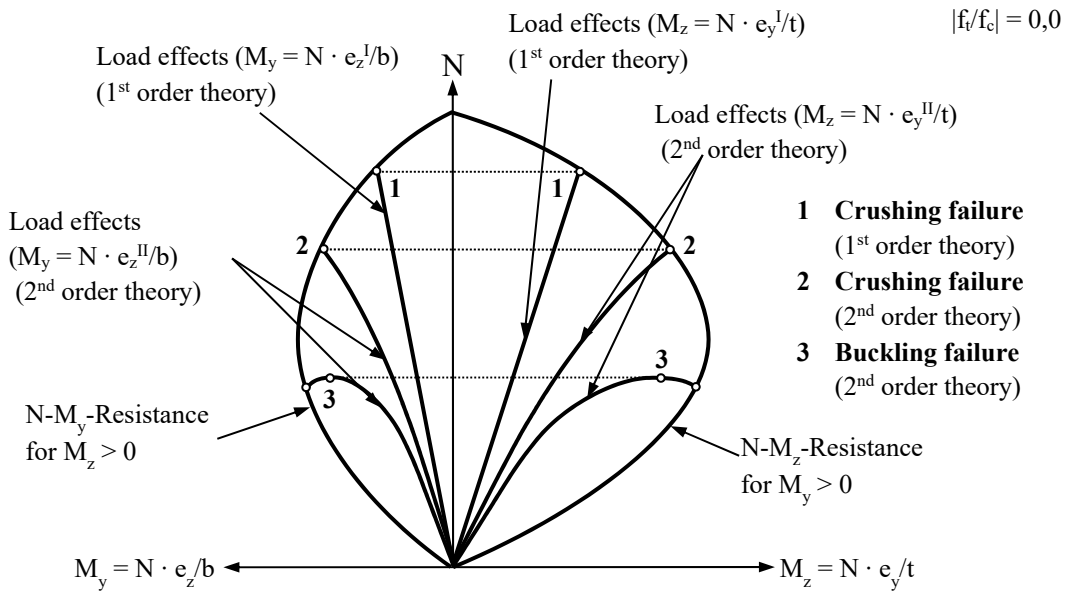

Figure 3: Normal force and bending moments for the cross section and loads [1]

The equilibrium with the greatest normal force is the load carrying capacity of the system. If load effects reach the resistance of the cross section, the compression member will fail due to crushing because the load carrying capacity of the cross section is exploited completely. This may occur considering 1st order theory (point 1 in Figure 3) or considering 2nd order theory (point 2 in Figure 3). These two failure modes always exists. In case of a material without flexural tensile strength, the maximum load carrying capacity can also lay within the resistance curve of the cross-section (point 3 Figure 3). In this failure mode, the load carrying capacity of the system is based on the equilibrium at the greatest normal force. Hence, if the point for the load carrying capacity of the system lies within the curve of the cross-sectional resistance, buckling failure will appear. Biaxial bending buckling failure may also occur if the point for one direction is within the cross-sectional carrying capacity but cross-sectional carrying capacity for the other direction is reached.

For a material without flexural tensile strength ($|f_t/f_c| = 0.0$) the different failure modes are shown in Figure 4 as a function of the slenderness. The quantity $|f_t/f_c|$ is the ratio of flexural tensile strength f_t to compressive strength f_c . The horizontal axis represents the slenderness and the vertical axis the normalised resisting normal forces considering 2nd order theory, $\Phi_R^{II} = N_R^{II} / (b \cdot t \cdot f_c)$. The curve of the load carrying capacity for materials without flexural tensile strength has an inflection point at the limit slenderness λ_{lim} . If the slenderness of the compression member is smaller than λ_{lim} , crushing failure will occur while if the slenderness is greater than λ_{lim} , buckling failure may occur.

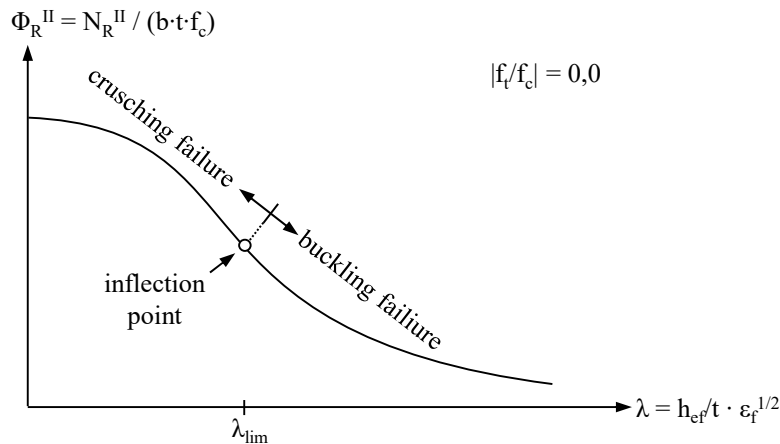

Figure 4: Load carrying capacity and different failure modes for materials without flexural tensile strength [1]

LOAD CARRYING CAPACITY CONSIDERING 2ND ORDER THEORY

A recognized method based on nominal curvature for concrete members which are eccentrically compressed in only one direction exists, see [2], [3], and [4]. This approach is also adopted in Eurocode 2 [5]. Considering 2nd order effects and shape of the curvature over the height of the compression member, the analysis can be reduced to the equilibrium of the critical cross section.

These principals were used in [6] to adopt this approach to unreinforced concrete and masonry walls which are loaded with unidirectional eccentric compressive forces. For linear-elastic materials, there is an analytical solution for crushing and stability failure considering 2nd order theory. As this approximation is only valid for the special case of unidirectional eccentric normal forces, the approach has to be extended to the general case of normal forces with biaxial bending. The principles of the derivation of the load carrying capacity are explained below.

For the determination of the load carrying capacity of slender compression members, it is necessary to consider 2nd order theory. The bending moments about each axis (M_y^{II} and M_z^{II}) can be determined by the following equations:

$$M_y^{\text{II}} = N \cdot e_y^{\text{I}} + N \cdot \Delta e_y^{\text{II}} \quad (1)$$

$$M_z^{\text{II}} = N \cdot e_z^{\text{I}} + N \cdot \Delta e_z^{\text{II}} \quad (2)$$

The exponent I stands for 1st order theory and II for 2nd order theory. The values e_y^{I} and e_z^{I} are the eccentricities of the normal force N and Δe_y^{II} and Δe_z^{II} are the deflections caused by the influence of 2nd order effects. These deflections can be calculated by the double integration of the curvature over the height of the compression member:

$$\Delta e_y^{\text{II}} = \int \int \kappa_z^{\text{II}}(x) dx dx \quad (3)$$

$$\Delta e_z^{\text{II}} = \int \int \kappa_y^{\text{II}}(x) dx dx \quad (4)$$

The values $\kappa_z^{\text{II}}(x)$ and $\kappa_y^{\text{II}}(x)$ describe the curvature distribution over the height x about each axis. Assuming the shape of the curvature, Equations 3 and 4 can be simplified to:

$$\Delta e_y^{\text{II}} = C_y \cdot h_{\text{ef},y}^2 \cdot \kappa_z^{\text{II}}(x=0) \quad (5)$$

$$\Delta e_z^{\text{II}} = C_z \cdot h_{\text{ef},z}^2 \cdot \kappa_y^{\text{II}}(x=0) \quad (6)$$

C_y and C_z are the constants of integration in each direction, $h_{\text{ef},y}$ and $h_{\text{ef},z}$ are the buckling lengths and $\kappa_z^{\text{II}}(x=0)$ and $\kappa_y^{\text{II}}(x=0)$ are the curvatures at the fixed support, see Figure 1 right. For sinusoidal curvature shapes, the constant of integration is $1/\pi^2 \approx 0.101$ and for parabolic shapes the constant is $5/48 \approx 0.104$. The approximation of the shape of the curvatures is the only approximation of the analytical model. For the design of reinforced concrete columns which are loaded eccentrically in one direction, Eurocode 2 uses 0.1 as the constant of integration [5].

Based on equilibrium at the critical cross section (Eq. 1 and 2) and considering the deflections (Eq. 5 and 6), the related moment-curvature relationship (shown in [1]) and the constants of integration, the load carrying capacity of the compression member can be determined. For some cases the load carrying capacity can be directly determined while for other cases, the load

carrying capacity must be calculated iteratively. Alternatively, the load carrying capacity can be calculated without using the approach of the curvature with a numerical model according to Equation 3 and 4.

NUMERICAL MODEL

The numerical model is based on a column with hinges at both ends and considers geometrical and physical nonlinearities. It discretizes the compression member by a defined number of elements. If the number of subdivisions is large enough, the deflections in both directions will be represented adequately and the computation of the load carrying capacity leads to a reasonably accurate solution. The calculations of the bending moments and curvatures will be done with the displacement method considering the 2nd order theory. For the calculation of the load carrying capacity of the compression member the applied load is increased step by step. The load carrying capacity is reached when the normal force cannot be increased any further.

For the stress-strain relationship of the numerical model, the equation of Eurocode 2 [5] is used:

$$\sigma(\eta) = \frac{k_0 \cdot \eta - \eta^2}{1 + (k_0 - 2) \cdot \eta} \cdot f_c \quad (7)$$

The value $\sigma(\eta)$ represents the stress, k_0 the degree of the non-linearity, η the ratio of the strain to the strain at maximal strength ($\eta = \varepsilon/\varepsilon_f$), f_c the compressive strength and ε_f describes the compressive strain at maximal strength of the stress-strain relationship, see Figure 5.

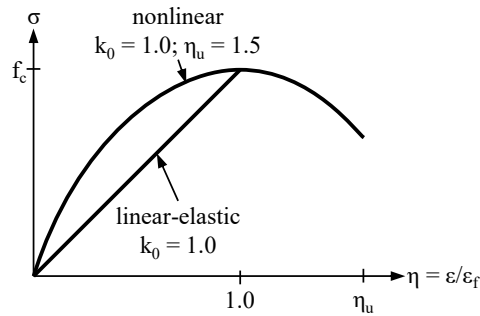

Figure 5: Stress-strain relationship of linear-elastic and nonlinear material [6]

The value k_0 is the normalised initial elastic modulus. The value $k_0 = 1.0$ represents a linear-elastic material, the value $k_0 = 2.0$ represents a material with parabolic stress-strain relationship and the value $k_0 \rightarrow \infty$ describes a rigid plastic material. The value η_u is the ratio of the maximal strain to the strain at maximum strength ($\eta_u = \varepsilon_{max}/\varepsilon_f$). A post-peak behavior exists only for $\eta_u > 1.0$.

LOAD CARRYING CAPACITY FOR THE UNCRACKED CROSS SECTION WITH LINEAR ELASTIC MATERIAL

The equations of the load carrying capacity of all five cases regarding crushing and buckling failure are very complex. In this paper only the equations for failure of the uncracked cross-section (case A) are presented. For all other cases see [1]. The analytical solution of the load carrying capacity (Φ_R^{II}) considering 2nd order theory for linear elastic material with and without flexural tensile strength is:

$$\Phi_R^{\text{II}} = \frac{1}{3} + \frac{\cos \left[\frac{2 \cdot \pi}{3} + \frac{1}{3} \cdot \arccos \left(\frac{A_1}{2 \cdot \sqrt{|A_2|^3}} \right) \right] \cdot \sqrt{A_2} + A_3}{216 \cdot A_4} \quad (8)$$

$$\text{with } A_1 = 2 \cdot A_5^3 + 1296 \cdot A_4 \cdot (432 \cdot A_4 - A_5 \cdot A_6)$$

$$A_2 = A_5^2 - 432 \cdot A_4 \cdot A_6$$

$$A_3 = 6 \cdot \left[C_y \cdot \lambda_y^2 \cdot \left(1 + 6 \cdot \frac{e_z^{\text{I}}}{b} \right) + C_z \cdot \lambda_z^2 \cdot \left(1 + 6 \cdot \frac{e_y^{\text{I}}}{t} \right) \right]$$

$$A_4 = C_y \cdot \lambda_y^2 \cdot C_z \cdot \lambda_z^2$$

$$A_5 = 2 \cdot A_3 + 144 \cdot A_4$$

$$A_6 = 12 \cdot (C_y \cdot \lambda_y^2 + C_z \cdot \lambda_z^2) + 6 \cdot \left(\frac{e_y^{\text{I}}}{t} + \frac{e_z^{\text{I}}}{b} \right) + 1$$

As Equation 8 is only valid for uncracked cross-sections, the slenderness and the eccentricities have to be limited as follows:

$$\lambda_y \leq \lambda_{y,\text{lim}} = \frac{1}{2 \cdot C_y} \cdot \sqrt{\frac{C_y \cdot \left\{ 1 + 6 \cdot \left(\frac{e_y^{\text{I}}}{t} + \frac{e_z^{\text{I}}}{b} \right) + 12 \cdot C_z \cdot \lambda_z^2 \cdot \left[1 - \Phi_{\text{lim,c}} \cdot \left(6 \cdot \frac{e_y^{\text{I}}}{t} + 1 \right) \right] - \frac{1}{\Phi_{\text{lim,c}}}} \right\}}{3 \cdot \Phi_{\text{lim,c}} \cdot \left[1 + 6 \cdot \frac{e_z^{\text{I}}}{b} + 12 \cdot C_z \cdot \lambda_z^2 \cdot (1 - \Phi_{\text{lim,c}}) - \frac{1}{\Phi_{\text{lim,c}}} \right]} \quad (9)$$

with $\Phi_{\text{lim,c}} = \frac{1}{2} \cdot \left(1 - \frac{f_t}{f_c} \right)$

and

$$\frac{e_y^{\text{II}}}{t} + \frac{e_z^{\text{II}}}{b} \leq \frac{1}{6} \cdot \frac{1 + \left| \frac{f_t}{f_c} \right|}{1 - \left| \frac{f_t}{f_c} \right|} \quad (10)$$

For the slenderness in both directions, materially normalised values have to be used:

$$\lambda_y = \frac{h_{ef,y}}{t} \cdot \sqrt{\varepsilon_f} = \frac{h_{ef,y}}{t} \cdot \sqrt{\frac{k_0 \cdot f_c}{E_0}} \quad (11)$$

$$\lambda_z = \frac{h_{ef,z}}{b} \cdot \sqrt{\varepsilon_f} = \frac{h_{ef,z}}{b} \cdot \sqrt{\frac{k_0 \cdot f_c}{E_0}} \leq \lambda_y \quad (12)$$

The value E_0 is the initial elastic modulus. The eccentricities in displaced condition may be calculated as follows:

$$\frac{e_y^{\text{II}}}{t} = \frac{\frac{e_y^{\text{I}}}{t}}{1 - 12 \cdot C_z \cdot \lambda_z^2 \cdot \Phi_R^{\text{II}}} \quad (13)$$

$$\frac{e_z^{\text{II}}}{b} = \frac{\frac{e_z^{\text{I}}}{b}}{1 - 12 \cdot C_y \cdot \lambda_y^2 \cdot \Phi_R^{\text{II}}} \quad (14)$$

Equation 8 can also be used for predicting the load carrying capacity of other linear-elastic materials with flexural tensile strength, for example steel and wood. If the flexural tensile strength is equal to the compressive strength, the limit slenderness for crushing failure according to Equation 9 is infinite. Hence, for these materials, crushing failure considering 2nd order theory always occurs. Conservatively, Equation 8 can be used for non-linear materials like unreinforced concrete with and without flexural tensile strength.

VERIFICATION OF THE ANALYTICAL MODEL

To verify the analytical model, numerical calculations were carried out. Figure 6 shows the load carrying capacities as calculated using the analytical model and the numerical calculations for linear-elastic material without flexural tensile strength ($|f_t/f_c| = 0$). The graph is valid for a slenderness ratio of $\delta = \lambda_y/\lambda_z = 2.0$ and a ratio of the eccentricities of $\psi^{\text{I}} = e_z^{\text{I}} \cdot t / (e_y^{\text{I}} \cdot b) = 2/3$. On the horizontal axis the slenderness parameter λ_y is shown whereas the vertical axis displays the normalised load carrying capacity considering 2nd order theory. For normalised resisting normal forces greater than 0.5 the cross section is uncracked and the compression member will fail due to crushing.

For very small eccentricities, $e_y^{\text{I}}/t = 0.01$ or $e_z^{\text{I}}/b = 0.01$, and buckling failure, the curve nearly represents the Euler hyperbola. For centrally compressed members, the analytical model with $C_y = C_z = 1/\pi^2$ exactly confirms the Euler hyperbola. As shown, there are only minor differences between the analytical model and the exact numerical calculation. For other ratios of δ and ψ^{I} , the differences between analytical and numerical model are similar. Thus the constants of integration $C_y = C_z = 1/\pi^2$ are sufficient to describe the shapes of the curvatures. Because

analytical and numerical model are independent, both models validate each other theoretically. Additional, in [1] the analytical and numerical model is validated with test results.

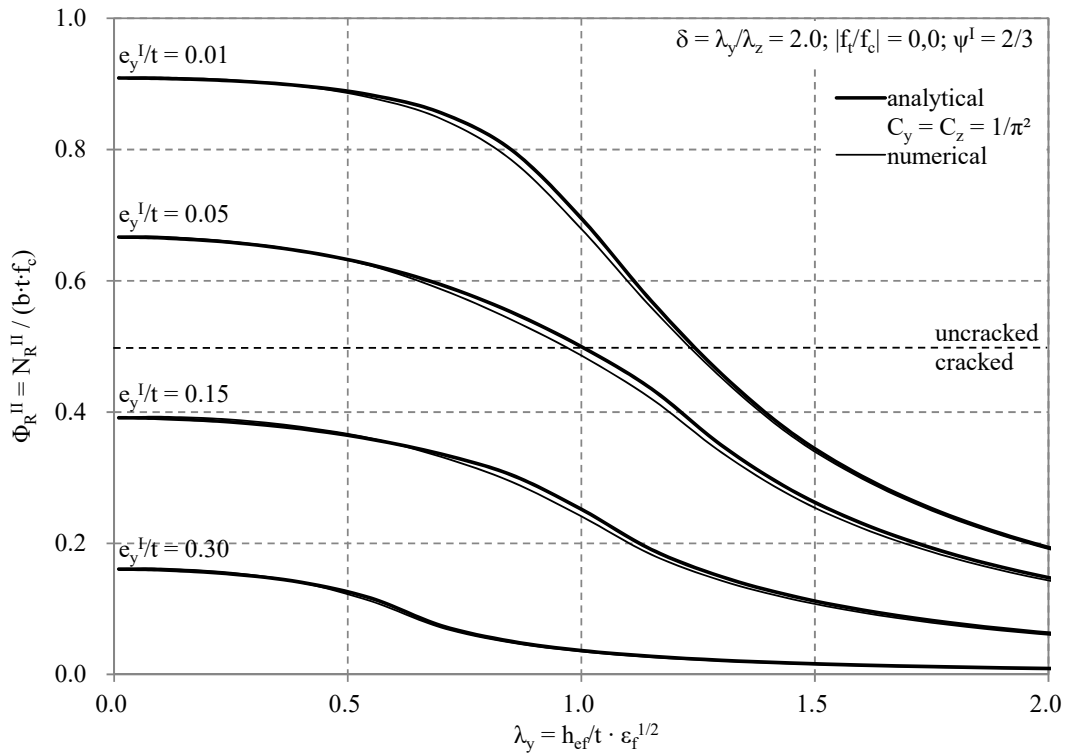

Figure 6: Comparison of the analytical model with the exact numerical calculation for linear elastic material without flexural tensile strength [1]

LOAD CARRYING CAPACITY FOR LINEAR ELASTIC AND PARABOLIC MATERIALS WITHOUT FLEXURAL TENSILE STRENGTH

Figure 7 shows the load carrying capacity for parabolic non-linear materials with post-peak behavior ($\eta_u = 1.5$) for a slenderness ratio of $\delta = \lambda_y/\lambda_z = 2.0$. For comparison, Figure 7 also shows the load carrying capacity for linear-elastic materials. The different quadrants of figure 7 illustrate different ratios of eccentricities ($\psi^I = e_z^I \cdot t / (e_y^I \cdot b)$). For $\lambda_y = 0$, Figure 7 displays the load carrying capacity of the cross-section. The system with non-linear material results in greater cross-sectional carrying capacities than the system with linear-elastic material. Also, for greater slenderness, the system with non-linear material results in greater load carrying capacities. This can be explained by the greater initial elastic modulus and same compression strength f_c and strain ϵ_f of the non-linear material. Because of the greater elastic modulus, the initial stiffness is greater and the deflections according to 2nd order theory are smaller which increases the load carrying capacity. Hence, for fixed strain, the linear-elastic material is the lowest limit for the load carrying capacity. Figure 7 can be used for the design of unreinforced masonry and concrete compression members.

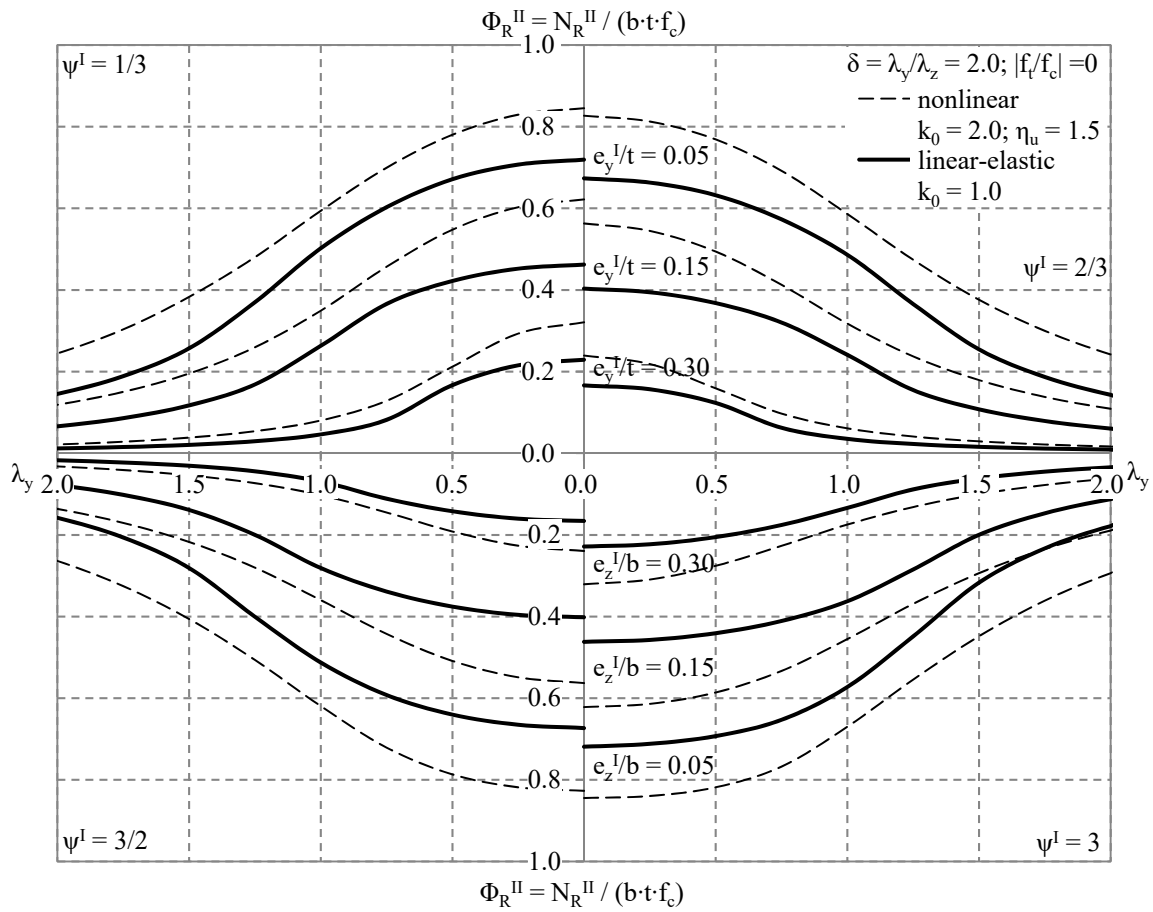

Figure 7: Comparison of load carrying capacity of linear elastic and non-linear material for various load settings [1]

SUMMARY

This paper presents the load carrying capacity of compression members loaded eccentrically in two directions. It presents the principles of an analytical model with linear-elastic material. The analytical solution for the load carrying capacity of uncracked compression members with and without flexural tensile strength is presented. The only approximation of the analytical model is the shape of the curvature over the height of the compression member, which is represented by the constants of integration. The approximation of the shape of the curvature by the constants of integration only has a minor influence on the load carrying capacity, which is verified with an accurate numerical model. Therefore the load carrying capacity can be accurately predicted with the analytical model. In addition, the increase of the load carrying capacity due to non-linear material is discussed based on results of numerical calculations.

REFERENCES

- [1] Förster, V. (in preparation). *Tragfähigkeit unbewehrter Beton- und Mauerwerksdruckglieder unter zweiachsig exzentrischer Normalkraftbeanspruchung*, doctoral thesis, Technische Universität Darmstadt, Germany.
- [2] Quast, U. (1970). *Geeignete Vereinfachungen für die Lösung des Traglastproblems der ausmittig gedrückten prismatischen Stahlbetonstütze mit Rechtquerschnitt*, doctoral thesis, Technische Universität Braunschweig, Germany.
- [3] Quast, U. (1970). „Traglastnachweis für Stahlbetonstützen nach der Theorie II. Ordnung mit Hilfe einer vereinfachten Momenten-Krümmungsbeziehung“ *Beton- und Stahlbetonbau*, 65 (1970), Heft 11, 165-271.
- [4] Kordina, K. and Quast, U. (1979). “Bemessung von Beton- und Stahlbetonbauteilen nach DIN 1045“ *Deutscher Ausschuss für Stahlbeton*, Heft 220.
- [5] DIN EN 1992-1-1 (2011-01). *Eurocode 2: Design of concrete structures – Part 1-1: General rules and rules for buildings*, German Version, DIN Deutsches Institut für Normung e. V., Berlin, Germany.
- [6] Glock, C. (2004). *Load-bearing capacity of unreinforced concrete and masonry walls – Model for non-linear analysis and consistent design concept for slender walls under compression*, doctoral thesis, Technische Universität Darmstadt, Germany, in German.