

HYBRID MASONRY DESIGN AND CONSTRUCTION PRACTICES

D.T. Biggs

Principal, Biggs Consulting Engineering, Troy, New York USA, biggsconsulting@att.net

ABSTRACT

Since it was introduced in 2007, hybrid masonry has been used in the United States to laterally brace buildings constructed with a steel frame. The system joins reinforced concrete masonry shear walls with a structural steel frame to provide in-plane shear resistance. The masonry also acts as support for out-of-plane loadings.

The hybrid system has been used in low and moderate seismic zones. On-going research at the University of Illinois and the University of Hawaii is now focusing on extending the system to high seismic zones. The research has been supported jointly by the masonry and steel industries and by the National Science Foundation Network for Earthquake Engineering Simulation (NEES).

Hybrid masonry offers designers and contractors economy and design flexibility for specific projects with both steel frame construction and masonry walls for the building's structure and enclosure. With the introduction of commercial structural software packages that can model and analyse hybrid systems, the system is now a viable engineering solution.

The International Masonry Institute (IMI) is assisting the research efforts by developed training programs for apprentice masons to construct mock panels of hybrid masonry. The training educates craftsmen and also provides confidence to designers and contractors that the system is both practical and economical.

This paper will discuss current and emerging design methodology and construction practices.

KEYWORDS: hybrid masonry, bracing, shear walls, frames, construction

INTRODUCTION

Hybrid masonry was introduced as a system concept at the 10th North American Masonry Conference [1]. The system is composed of structural steel frames and reinforced concrete masonry panels. The system offers a design alternative to braced frames and moment-resisting frames. Height limitations have not been firmly established but studies indicate that up to eight stories are feasible. For the current research, the panels are solid with no openings. Criteria for reinforced wall panels with openings will be developed in the future.

Unreinforced masonry panels have been used within concrete bounding frames for buildings throughout the world [2]. However, few panels if any have used reinforced masonry. Therefore, the hybrid masonry system is distinctly different from previous systems. Some differences are listed in Table 1.

Table 1 - Differences - Unreinforced Masonry within Frames versus Reinforced Hybrid Masonry

	Masonry panels within Frames	Hybrid Masonry	Notes
Type of masonry	Unreinforced	Reinforced CMU	Few projects with masonry within frames have been reinforced.
Masonry construction	Built tight to bounding frame.	Three types with different connectivity.	The performance of the hybrid masonry is dependent upon the connectivity.
Connectors to frame at tops of walls	None typically used.	Mandatory	Hybrid masonry relies upon steel connectors at columns and beams.
Frame construction	Concrete or structural steel. Braced frame or moment-resisting.	Structural steel. Braced frame or moment-resisting.	Research for hybrid masonry has concentrated on structural steel. Concrete frames will be a future development.

Similar to the unreinforced masonry in frames, reinforced concrete masonry panels in hybrid masonry provide strength and stiffness both for in-plane and out-of-plane loads. While the unreinforced masonry within frames is constructed tight to the concrete frame and relies upon mortar bond and friction for connectivity, hybrid masonry relies on mechanical connectors to the bounding frames. Mechanical connectivity is essential to provide a reliable seismic connection that does not depend upon friction. The type of connectors and the interface between the masonry panels and the frame determine the overall performance of the system. This leads to three different types of hybrid masonry systems (Figure 1). The panel connections [3] transfer shear forces between the steel frame and the masonry panel and essentially control the hybrid masonry panel performance for each of the systems [4].

Since 2009, research for hybrid masonry has concentrated on using structural steel frames. Concrete frames will be a future development. The structural steel frame can be either a braced frame with the masonry panels serving as the entire lateral bracing or a moment-resisting frame which shares the lateral load with the masonry panels based upon relative stiffness.

DESIGN AND CONSTRUCTION ISSUES

The structural steel frame design is addressed elsewhere [5]. The masonry panel interaction will be highlighted in this paper. In all cases, the masonry panels are in the plane of the steel frame.

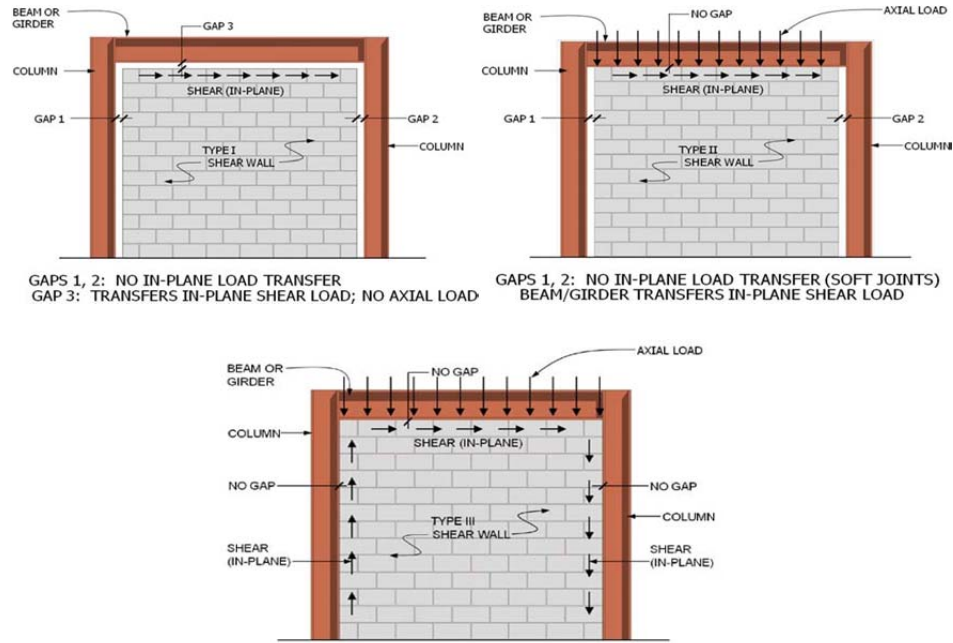

Figure 1 - Hybrid masonry types I, II and III

Figure 2 highlights the various elements of the hybrid systems that will be mentioned in this paper.

Hybrid elements

- Connectors (top) between frame and masonry.
- Connectors (sides) between frame and masonry.
- Connectors at base of panel.
- Wall panel; loads; R value.

Steel frame

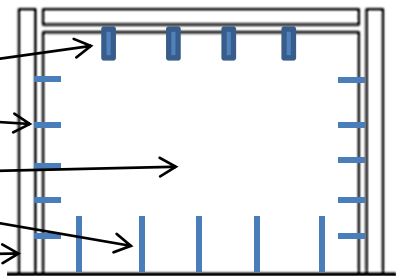

Figure 2 - Masonry design and construction issues

TYPE I HYBRID PANELS

There are two variations of Type I hybrid panels. The overall Type I system includes gaps around the panels such that the frame does not contact the panel during lateral drift as seen in Figure 1.

a. Top Connectors

The entire lateral load is transferred between the top of the panels and the frame by connectors, either link plates (Figure 3a) or fuse plates (Figure 3b). These connectors are vertically slotted and transfer only horizontal loads.

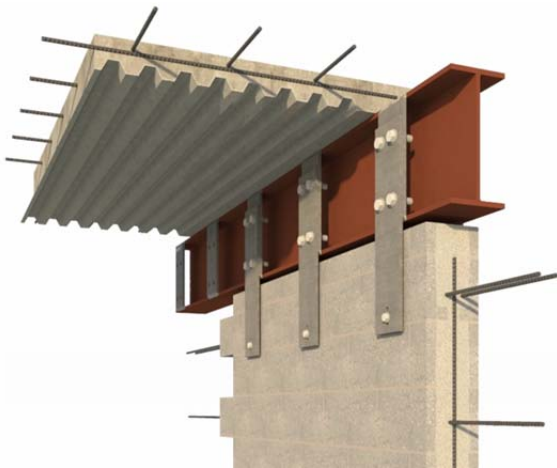

Figure 3a - Link plate connectors



Figure 3b - Fuse Connectors

Link plates are rigid plates welded or bolted to the frame that provide high strength but little ductility (Figure 4). Fuse plates are similarly connected but are detailed to have a yielding zone that provides ductility which is especially necessary in seismic designs (Figure 5). In Figures 4 and 5, 25 mm bolts were used to attach the connector plates to the steel frame for easy replacement after a significant earthquake; however, they could have been welded.

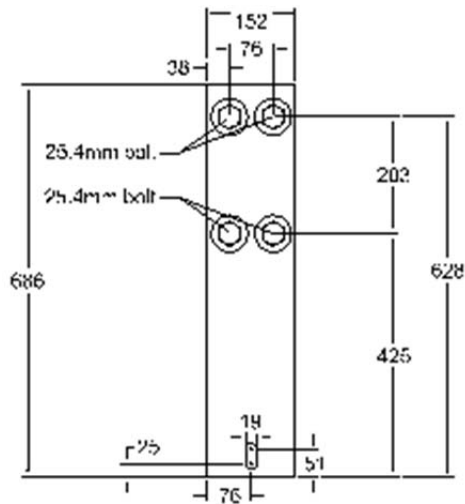

Figure 4 - 12.5 mm thick link plate and load-displacement curve

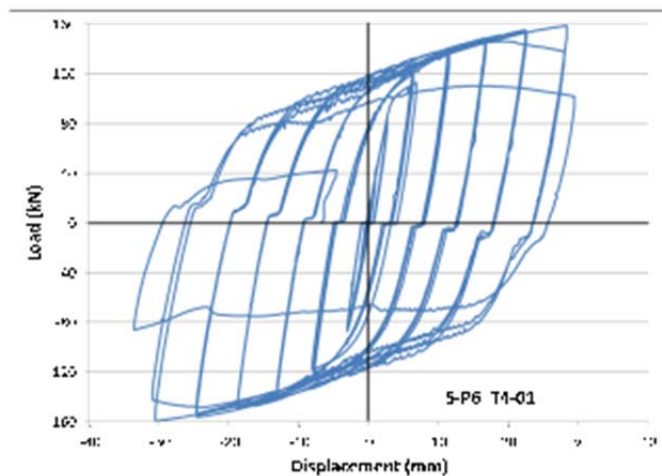

Figure 6 shows one of the fuse plates during testing. Both types of connectors transfer their lateral load to the masonry panels by bolts; through bolts have been the preferred method. From a design and construction standpoint, the spacing of the through bolts and the edge distance to the panel are important features because they are the primary elements for transferring loads. Aoki et al [6] provides the developmental background for the through bolt connections.

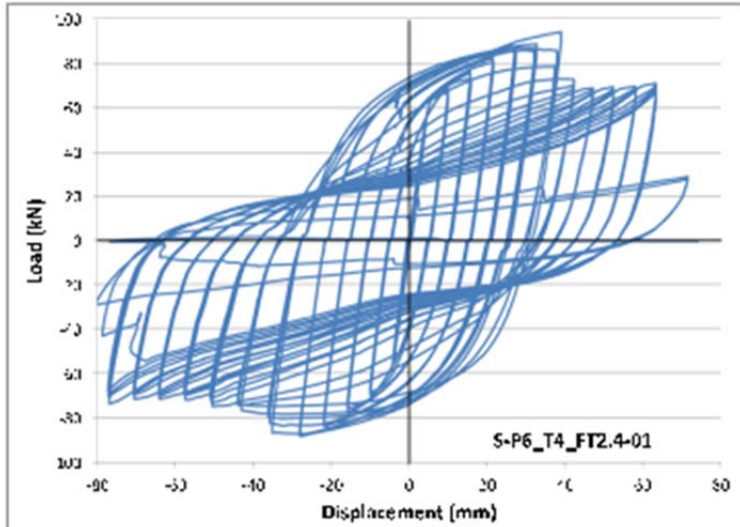
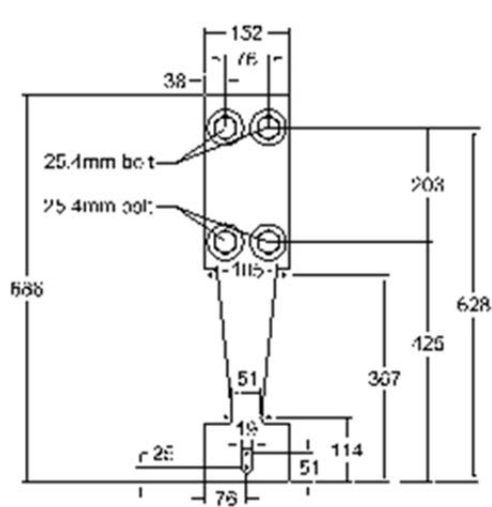

Figure 5 - 12.5 mm thick fuse plate and load-displacement curve



Figure 6 - Fuse plate connector with ductile flexing

Table 2 shows tested capacities [7] specifically for the 152 mm plates shown in Figures 4 and 5. Other plate sizes would be different. For design purposes, it is recommended to use the yield point values for the links due to their lack of ductility while the ultimate values are used for the fuses. Until further testing is performed, tested values should be reduced by 50% to determine design values. Additional research is necessary for other non-through bolt types and configurations. Table 2 also gives tested values for 19 mm (3/4 in.) through bolts that connected the plates to the masonry. These values are governed by the breakout capacity of the masonry [6].

Table 2 - Type I Hybrid Connector Tested Capacities

Connector Type	Load capacity/ plate	Load capacity of 25mm through bolt ¹
12.5 mm link plate x 152mm	67kN (yield)	89kN (20.0 kips)
12.5 mm fuse plate x 152mm	67kN (ultimate)	89kN (20.0 kips)

¹Based upon prism strength = 18.8 MPa with 200mm nominal CMU [6]

From a construction standpoint, the tops of the masonry panels require a continuously grouted reinforced bond beam course (shaded course in Figure 7) to transfer the shear forces from the through bolts. The through bolts are placed below the horizontal reinforcement in the bond beam. The bolts and connector plates are also designed to transfer out-of-plane loads from the panels to the frame [8].

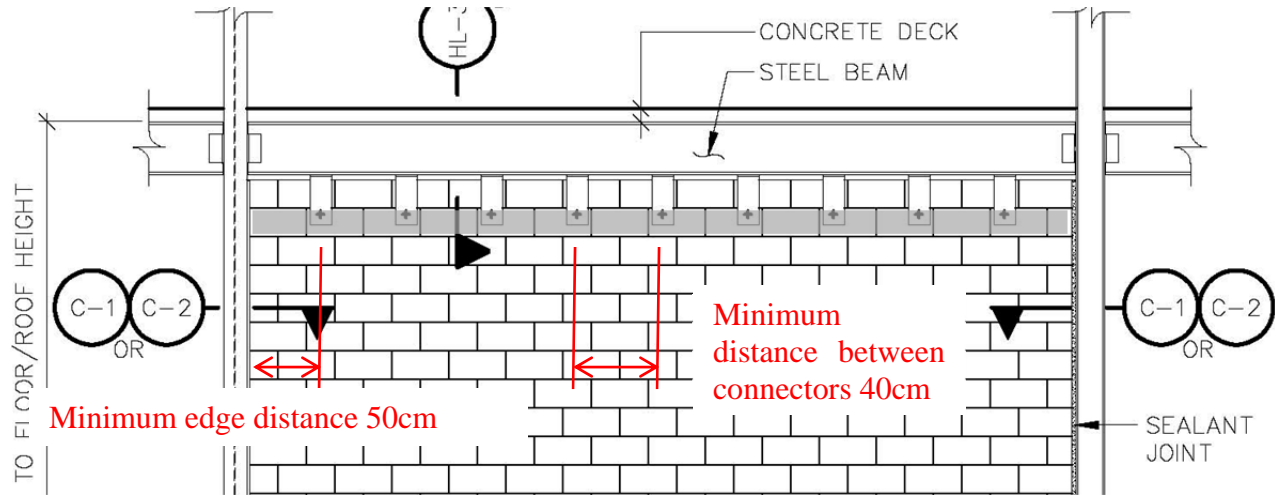

Figure 7 - Bond beam at top of panel

b. Side Connectors

Unlike a masonry bearing wall building, hybrid panels must address the connectivity at steel columns. If the panels span vertically for out-of-plane loads, no connection at the columns are necessary. However, there are standard masonry connectors which can be used to stiffen the panels for out-of-plane action. These connectors should not transfer in-plane loadings (Figure 8).

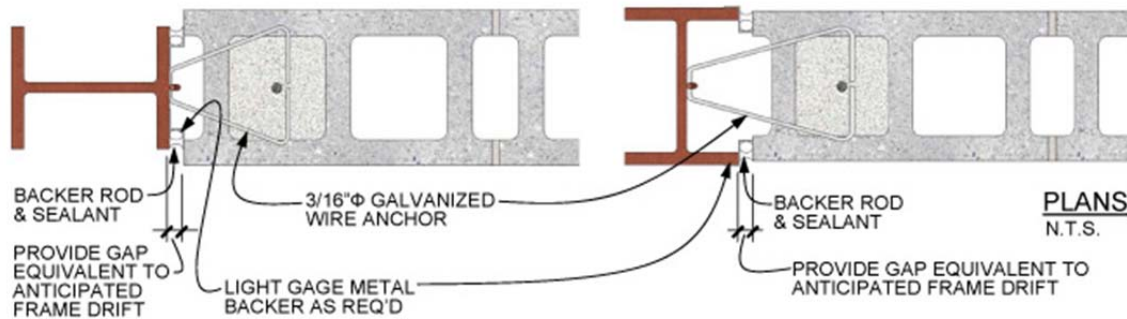

Figure 8 - Column details [8]

c. Base Connectors

As with any shear wall, the base of the panels must transfer in-plane shear loads and out-of-plane loads. At floor levels, load transfer can be accomplished with reinforcement dowels provided the dowels are developed for the tie down forces (Figure 9). For panels at the first level, the dowels are embedded in the foundation walls or grade beams.

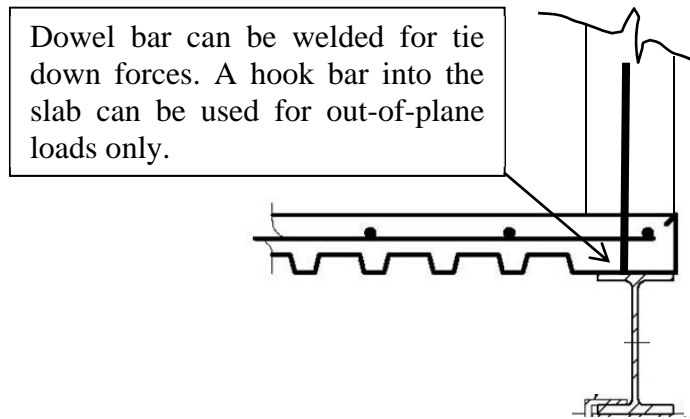

Figure 9 - Tie down detail

d. Wall Panels

The masonry panel is designed similar to a non-load bearing shear wall. The type of masonry panel (partial or fully grouted) is a function of the loadings and the seismicity. Vertical reinforcement must be developed to provide shear resistance at the bond beam interface with the courses below.

Based upon current research [10], designs for buildings in seismic design categories (SDC) C and higher are recommended to be special reinforced shear walls which are fully grouted. The R value for design presents some challenges. Masonry panels with link plates are suited to an R=3 provided the panel is an intermediate reinforced or special reinforced masonry shear wall [11]. Special reinforced shear walls with fuse connectors can perform to an R=5 or greater value. However, the designer may select a lesser R to simplify the structural steel design.

Since the masonry panel is in the plane of the steel frame, installing the reinforcement and grouting the panel is often a concern. The IMI has been vetting construction methods and details are provided on their web site for both low-lift and high-lift grouting. Figure 9 shows one detail for low-lift grouting. In all the details, the second course from the top of the panel is the grouted bond beam. The top course is either a full or partial height course dependent until the depth of the steel beam.

TYPE II HYBRID PANELS

There are two variations of Type II hybrid panels that will be discussed later. The overall Type II system includes gaps on the sides while the panel is in contact with the framing at the top as seen in Figure 1.

a. Top Connectors

The entire lateral load is transferred between the top of the panels and the frame by connectors using 19mm (3/4 inch) headed studs x 15 cm long (Figure 10). The masonry panel is designed similar to a load bearing shear wall. The type of masonry panel (partial or fully grouted) is a function of the loadings and the seismicity. Vertical reinforcement must be developed into the bond beam to provide shear resistance at the bond beam interface with the courses below. The

connectors should be provided with a minimum spacing of 40cm and a minimum edge distance of 30 cm.

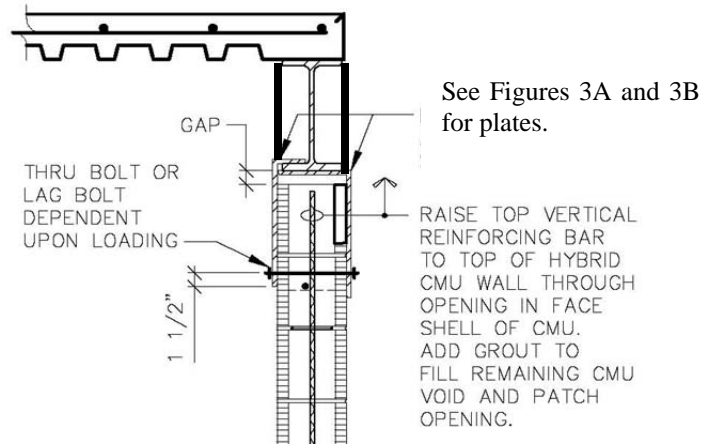

Figure 9 - Example detail [9]

Connector	Tested capacity per stud ¹
19 mm headed stud x 15 cm long.	89 kN (20 kips)

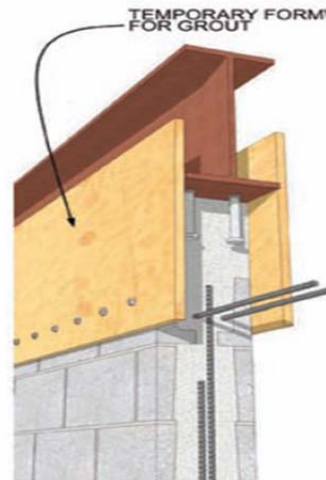

Figure 10- Type II hybrid panel with headed studs

b. Side Connectors

The connectors to the columns are similar to the previous discussion on Type I hybrid panels.

c. Base Connectors

The base connectors are similar to Type I expect that if the tie down forces are not resisted by the dowels, the dowels need only transfer in-plane and out-of-plane shear.

d. Wall panels

The two variations of Type II hybrid panels are a function of the development of the overturning. The first variation is the traditional load bearing shear wall concept. The overturning is resisted

by a tie down element. However due to the frame confinement, the frame also contributes to the overturning resistance (Figure 11).

The second variation is where the tie down element (T in Figure 11) is ignore and the panel confinement takes the total overturning. Essentially, the steel frame columns become the boundary elements for the panel.

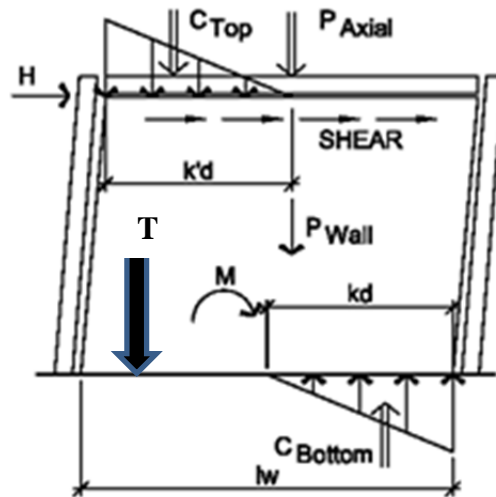

Figure 11 - Type II hybrid using confinement for overturning resistance

The design values for R are similar to the previous discussion on Type I hybrid panels. In both cases the design methodology for the panel is similar to load bearing masonry.

From a construction standpoint, the tops of the masonry panels require a continuously grouted reinforced bond beam course to transfer the shear forces from the headed studs.

TYPE III HYBRID PANELS

The Type III hybrid panel in Figure 1 shows that the masonry is fully confined by the frame. The confinement is expected to provide a unique performance to the system. While the Type I and Type II hybrids panels perform mainly like non-load bearing and load bearing panels respectively, the Type III panel is expected to perform as a composite with the frame. Research is still on-going for the Type III hybrid panels and will be addressed in future papers. The comments provided below are based upon current expectations and preliminary results.

a. Top Connectors

The lateral load is transferred between the top of the panels and the frame by connectors using headed studs similar to Type II hybrid in addition to the panels being in contact with the columns (Figure 12). Research will address the sharing of lateral loads.

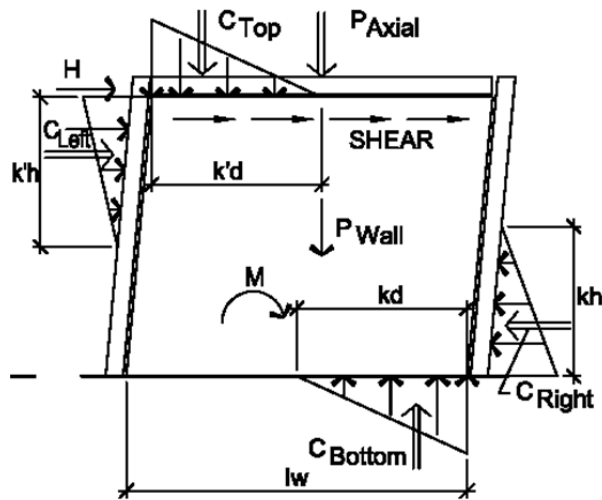

Figure 12 - Type III hybrid

b. Side Connectors

The panels are expected to transfer in-plane shear to and from the steel frame columns. Thus, headed studs or rigid strap anchors are being tested in upcoming research. These anchors are to be designed for each project to transfer in-plane shear and out-of-plane shear between the columns and the panel adding to the composite nature of the frame and the panels. The anchors should be grouted to the column (Figure 13).

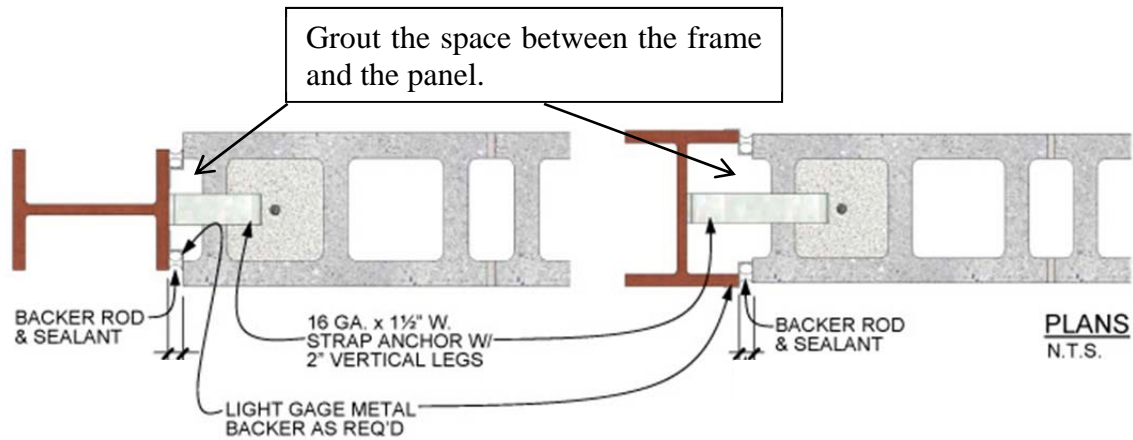

Figure 13 - Type III hybrid side connectors

c. Base Connectors

The base connectors are expected to be similar to Type I hybrid.

d. Wall Panels

From a construction standpoint, the panels are constructed similar to the Type II hybrid with the added feature that the sides of the panels are connected to the columns (Figure 13). Research is still on-going for the Type III hybrid panels. Design issues will be addressed in future papers.

SUMMARY

Hybrid masonry is being used in low seismic regions of the United States. On-going research indicates the potential to perform well in high seismic regions also. The research has focused primarily on Type I and II hybrid panels; Type III is slated for study in 2013.

ACKNOWLEDGEMENTS

Research described in this paper is supported by the National Science Foundation under Grant No. CMMI 0936464, as part of the George E. Brown, Jr. Network for Earthquake Engineering Simulation. Appreciation is extended to all team members of this research. Partial support from the American Institute of Steel Construction, the National Concrete Masonry Association, and the International Masonry Institute is gratefully acknowledged.

REFERENCES

1. Biggs, D.T. (2007) "Hybrid Masonry Structures," 10th North American Masonry Conference, St. Louis, Missouri, USA, pp. 825-837.
2. Walkowicz, Scott W. (2010). "Steel Framing with Masonry Walls – An Historical Perspective", 2010 ASCE Structures Congress, Orlando, FL, USA on CD.
3. Johnson, G., Robertson, I.N., Goodnight, S., Ozaki-Train, R., (2011), 11th North American Masonry Conference, Minneapolis, MN, USA, on CD.
4. Asselin, R.E., Fahnestock, L.A., Abrams, D.P. (2011), "Feasibility of Hybrid Masonry in Seismic Regions", 12th Canadian Masonry Symposium, Vancouver, BC, CN, on CD.
5. Asselin, R.E., Fahnestock, L.A., Biggs, D.T., (2013), "Design of Hybrid Masonry Systems", 2013 ASCE Structures Congress, Pittsburgh, PA, USA, on CD.
6. Aoki, J.M., Robertson, I.N., "Steel-masonry Interface Strength and Behavior", 12th Canadian Masonry Symposium, Vancouver, BC, CN, on CD.
7. Ozaki-Train, R., Johnson, G., Robertson, I.N., (2011), "Hybrid Masonry Connector Development-Phase II", Research Report UHM/CEE/11-04, December 2011, University of Hawaii, College of Engineering, www.cee.hawaii.edu/content/resreport.htm
8. Biggs, D.T. (2011), "Using Hybrid Masonry Bracing For Steel Frames", 11th North American Masonry Conference, Minneapolis, MN, USA, on CD.
9. International Masonry Institute, (2009), Structural Masonry, Hybrid Masonry/Steel Details, http://www.imiweb.org/design_tools/structural_masonry/details_hybrid.php
10. Abrams, D.P. (2013), "NEES Research On Hybrid Masonry Structural Systems", 12th Canadian Masonry Symposium, Vancouver, BC, CN, on CD.
11. ASCE (2010), "ASCE/SEI 7-10, Minimum Design Loads of Buildings and Other Structures", American Society of Civil Engineers, Reston, VA, USA