



EXPERIMENTAL SMALL-SCALE ANALYSIS OF THE CONNECTIONS BETWEEN STRUCTURAL CLAY BLOCK WORK MASONRY WALLS SUBMITTED TO VERTICAL LOADS

M.R.S. Corrêa¹, E.M.S. Moreira² and M.A. Ramalho³

¹ Associate Professor, Engineering School of São Carlos, University of São Paulo, mcorrea @sc.usp.br

² Civil Engineer, MSc, University of São Paulo, elian.moreira@yahoo.com.br

³ Associate Professor, Engineering School of São Carlos, University of São Paulo, ramalho@sc.usp.br

ABSTRACT

This work presents a comparative analysis of three types of connections between H-shaped structural clay block walls under vertical loads. The first type is a set of running bond interconnected masonry walls. The second connection is obtained by means of steel trusses and the third one, also stack bond, is tied by steel U-staples anchored in grouted holes. The study is based on an experimental program carried out in the Laboratory of Structures of the University of Sao Paulo at Sao Carlos. The test specimens are H-shaped third scale walls, with five courses, as proposed by Capuzzo Neto [1]. The experimental analysis allows for the evaluation of the shear strength of the vertical interface between the central wall and the flanges. The study shows that the running bond specimens provide the largest shear strength and a brittle failure type. Both the stack bond specimens present shear strength of roughly 60% of the running bond type, with a tendency for ductile failure, especially for the stapled connection.

KEYWORDS: structural masonry, clay blocks, connections, steel meshes, interaction, small scale models.

INTRODUCTION

Wall interaction occurs by force transference along the common interface, which when effective can lead to substantial increases in capacity. Wall interaction is well recognized and accepted for horizontal loading and many codes allow for the consideration of web-flange interaction to enhance the stiffness of shear walls. Interaction also occurs when intersecting walls are subjected to different compressive stresses. The trajectories of the vertical stresses across the wall height also depend on the way walls interact.

The type of connection between the walls influences the way interaction occurs. In bonded walls, interaction can be high because the interface plane crosses not only head joints, but also units (bricks and blocks), which may be considered common to the connected walls.

Alternatively, when the walls are not bonded, other structural elements can be used to tie the walls, say horizontal steel bars or trusses, or U steel bars (staples) anchored into grout poured in vertical block holes near the interface. As well as the cited connectors, bond beams are usually provided, made of lintel blocks and filled up with poured grout and steel horizontal bars.

There are only a few number of research projects dealing with experiments to evaluate shear strength at vertical wall interfaces. Simundic [2] tested a series of diaphragm H-shaped walls made of nine courses of bricks with various types of ties. Lissel et al [3] evaluated the influence of the type of ties used in interconnected blockwork walls. Camacho et al [4] tested different small scale specimens made of clay blocks: 9 course H-shaped walls, small rack prisms and isolated blocks to determine the shear strength of interfaces. Silva [5] repeated Camacho’s tests with full scale specimens. Bosiljkov et al [6] developed an analytical study based on Simundic’s experiments, using a complex Finite Element modelling to simulate the specimens’ behaviour. Cappuzo Neto [1], after studying the interaction of clay blockwork walls subjected to vertical loading [7], developed a research project in SET/EESC/USP to shed light on the subject. This study included a proposal of a test to assess the shear resistance of vertical interfaces of masonry interconnected walls [8], which is briefly described in the following sections. Using the developed specimen and test apparatus another paper [9] discussed the influence of the bond beams on the interface resistance of running bond interconnected walls, focusing on third-scale clay blockwork. Following the same guidelines, Moreira [10] developed a research program to evaluate the shear strength of vertical interfaces, considering three alternative types of interconnection: running bond, stack bond with horizontal steel trusses and stack bond with U steel bars anchored into grouted vertical block holes. This paper describes the main findings of the mentioned project, showing the experimental program, the obtained results and its key conclusions. It is important to highlight that the obtained resistance can be used either to verify shear at the wall interface caused by vertical load distribution, horizontal loading or both acting together.

PROPERTIES OF THE MATERIALS

Blocks

All the tests were carried out using third scale models to make the test apparatus and procedures easier, cheaper and viable. The validity of this and the scale factors for the natural scale were previously developed by [1].

The third-scale clay block dimensions are shown in Table 1. They are equivalent to a 150 by 300 by 200mm full size unit module.

Table 1: Geometrical nominal dimensions of the third-scale blocks

	Type of block	Thickness (mm)	Length (mm)	Height (mm)
Block	47	97	63	
Half Block	47	47	63	
U-block	47	97	63	

Table 2 presents the average results for compressive and tensile strengths and the Young's modulus of the blocks, using 29, 12 and 6 specimens respectively. The results are based on the gross area, except the tensile strength that is assessed with the actual thickness of the webs.

Table 2: Mechanical properties of the third-scale blocks – average values

	Compressive strength (MPa)	Indirect tensile strength (MPa)	Young's modulus (GPa)
Average	30.31	5.91	11.1
C.O.V.	22.1%	10.0%	18.4%

Mortar and grout

The adopted mortar mix proportion was 1:0.5:4.5 (cement, lime and sand), by volume, and a water/cement ratio of 1.2. Very fine sand was used to keep the maximum grain dimension within the limit of one third of the thickness of bed and head joints, which was 3mm. Three cylindrical mortar specimens (50mm x 100mm) were built to measure the compressive strength, during the characterization phase. The average value was 10.32 MPa with a C.O.V. of 18.8%.

The mass proportion of the grout used to fill the top course U-blocks and the vertical holes was 1:0.76:1.24 (cement: sand: gravel) with a water/cement ratio of 0.37 and an addition of 1.1% of a super plasticizer. Three cylindrical grout specimens (50mm x 100mm) were cast to evaluate the compressive strength, whose average value was 63.70 MPa (C.O.V.= 15.8%).

Reinforcement of the bond beam and steel connectors

One steel bar of 4.2mm diameter and a 600 N/mm² yield limit was inserted into each bond beam (Figure 1a).

The steel trusses placed at each course as connectors were square 4mm meshes made of 0.70mm diameter galvanized wires (Figure 1b).

The staples inserted into each course with the same aim were made of steel bars of 2.74mm diameter and a 458 N/mm² yield limit (Figure 1c).

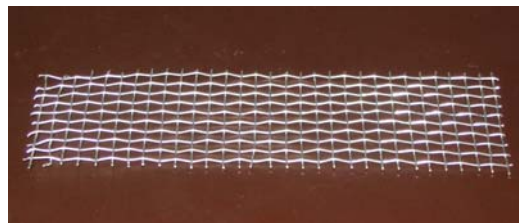

40 mm x 147 mm



46mm x 53mm x 46mm

Figure 1: a) Steel bars in the bond beam; b) Steel truss; c) Steel staple

EXPERIMENTAL PROGRAM

Description of the tests

Based on previous evidences [1] the present study adopted all the tests on a small scale (1:3), because of their simplicity and feasibility. The third scale specimens had the dimensions and row arrangements proposed by [1] (Figure 2a). All the specimens had a bond beam at the top.

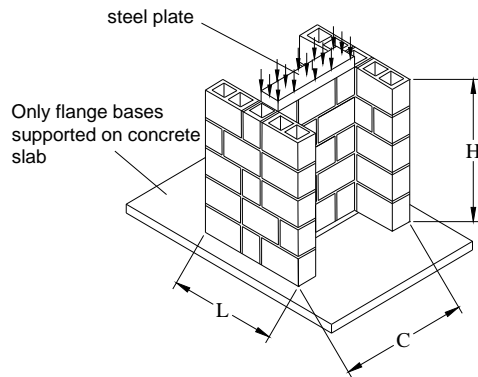

Third scale
L = 247mm
C = 297mm
H = 327mm



Figure 2: a) Specimens' dimensions; b) Test apparatus

Three distinct situations were investigated: running bond interconnected walls (Figure 3a); web and central walls connected by steel trusses at each course (Figure 3b) and web and central walls connected by steel U-staples inserted into each course anchored in adjacent vertical holes (Figure 3c).



Figure 3: Vertical interfaces: a) Running bond (RB); b) Stack bond connected by steel trusses (SBT); c) Stack bond connected by steel U-staples (SBS)

The same expert bricklayer built all the samples, using an aluminium reference frame. Regarding each type, every specimen was replicated six times, including two 3-block prisms and three cylindrical (50mm x 100mm) mortar specimens to evaluate the components' properties. Head and bed joints were built with a 3mm thickness across the full width of the units for the head joints. The sand was very fine.

It is worth noting that all the tests were carried out at a minimum age of 28 days and that the H-specimen test and the corresponding control tests (mortar and prisms) were always performed at

the same age. Vertical loads were applied to the web top and only the flange bases were supported. The average shear strength was assessed by the ratio of the failure load to the vertical interfaces area (2 x unit thickness x specimen height). The web top was capped with dental plaster and plywood plates, before placing the steel plate to provide a uniform load distribution. A few initial cycles of small vertical loads were applied in order to bed the specimens and check the instrumentation. All the tests were carried out in a servo controlled hydraulic jack INSTRON with an initial speed of 0.01mm/s, reduced to 0.002mm/s near the failure load. Figure 2b shows the test apparatus.

Test results

Tables 3, 4, and 5 show, respectively, the obtained results of the third scale tests of the three different types of specimens. Each table includes: the load corresponding to the appearance of the first crack, the failure load, the shear strength of the vertical interface and the compressive strength of the mortar and 3-block prisms related to each specimen. The results for interface and prism strength are based on the gross area.

Table 3: Results for third-scale specimens – running bond vertical interface

Specimen RB	1rst Crack Load (kN)	Failure Load (kN)	Interface Shear Strength (MPa)	Mortar Comp. Strength (MPa)	Prism Comp. Strength (MPa)
1	42.00	92.30	3.00	8.95	11.73
2	37.00	63.30	2.06	8.78	10.95
3	40.00	78.60	2.56	8.84	13.57
4	42.00	70.40	2.29	7.86	14.08
5	39.00	82.30	2.68	7.35	11.46
6	41.00	74.60	2.43	10.86	15.40
Average	40.17	76.92	2.50	8.77	12.87
Stand. Dev.	1.94	10.02	0.33	1.21	1.75
C.O.V.	4.8%	13.0%	13.0%	13.7%	13.6%

Table 4: Results for third-scale specimens - Stack bond connected by steel trusses (SBT)

Specimen SBT	1rst Crack Load (kN)	Failure Load (kN)	Interface Shear Strength (MPa)	Mortar Comp. Strength (MPa)	Prism Comp. Strength (MPa)
1	45.00	51.70	1.68	9.71	13.73
2	35.00	38.70	1.26	10.58	15.95
3	38.00	46.50	1.51	8.90	13.59
4	33.00	41.10	1.34	11.36	18.04
5	37.00	43.10	1.40	10.08	12.98
6	31.00	36.00	1.17	10.25	14.95
Average	36.50	42.85	1.39	10.15	14.87
Stand. Dev.	4.89	5.64	0.18	0.83	1.88
C.O.V.	13.4%	13.2%	13.2%	8.2%	12.7%

Table 5: Results for third-scale specimens - Stack bond connected by steel U-staples (SBS)

Specimen SBS	1rst Crack Load (kN)	Failure Load (kN)	Interface Shear Strength (MPa)	Mortar Comp. Strength (MPa)	Prism Comp. Strength (MPa)
1	40.00	46.50	1.51	8.13	12.10
2	40.00	53.60	1.74	12.63	12.09
3	30.00	39.10	1.27	11.46	16.62
4	30.00	30.40	0.99	12.70	10.04
5	40.00	58.80	1.91	13.31	12.95
6	42.00	61.30	1.99	13.92	14.34
Average	37.00	48.28	1.57	12.03	13.02
Stand. Dev.	5.48	11.96	0.39	2.08	2.25
C.O.V.	14.8%	24.8%	24.8%	17.3%	17.4%

Analysis of the results

The test for assessing the compressive strength of the blocks, with 29 specimens, which led to the aforementioned average of 30.30 MPa produced results with a C.O.V. of 22.1%. The large C.O.V. is the liable explanation for the differences on the prisms average compressive strengths in the three former tables (12.87, 14.87 and 13.02 MPa), since the influence of the mortar strength is low.

The comparison of the shear strength of the vertical interfaces for all the three types of specimens shows that the running bond is the strongest one. The obtained values of the C.O.V. are close to 13% for the RB and SBT specimens and higher for the SBS specimens that produced a CO.V. of 24.7%. Table 6 summarizes the main results. The use of the ANOVA test to compare them, having a 5% level of significance, shows that the stack bond specimens are significantly different from the running bond ones. The same test, with the same level of significance, shows that the differences between the stack bond specimens (SBT and SBS) are not significant. Note that the analysis of the shear strength of the interface can be extended to the failure load since that strength is assessed by the ratio of the failure load to the gross area of the vertical web-flange interfaces.

Table 6: Comparison of the interface shear strength for the different third-scale specimens

Type of connection	Interface Shear Strength (MPa)	Ratio to RB
RB	2.50	1.00
SBT	1.39	0.56
SBS	1.57	0.63

Dealing with third-scales RB specimens made with the same blocks, Capuzzo Neto [1] obtained an interface shear strength of 2.76 MPa (average value), only 10% higher than the result of 2.50 MPa. Another test was carried out with a full scale specimen aiming the comparison between different scale models. The author reports that the failure modes were very similar and that the

scale factor was roughly 2.0, i.e. the third-scale specimens were twice as strong as the full-scale corresponding ones.

It is worth mentioning that the ANOVA test applied to compare the load at which the first crack appears, shows that the differences are not significant for the three types of specimens. Table 7 summarizes the main results, taking the average values. The similarity of the results for the stack bond specimens was somewhat expected due to the use of steel connectors in both. However the similarity to the running bond specimens was a remarkable result. The authors intend to investigate more to find out plausible reasons for that.

Table 7: Comparison of the 1rst crack load for the different third-scale specimens

Type of connection	1rst Crack Load (kN)	Ratio to RB
RB	40.17	1.00
SBT	36.50	0.91
SBS	37.00	0.92



Figure 4: Comparison of typical failure patterns: a) Running bond (RB); b) Stack bond connected by steel trusses (SBT); c) Stack bond connected by steel U-staples (SBS)

The typical failure patterns shown in Figure 4 show the central web walls at the top and the flange walls at the bottom for the three types of connections. The cracking schemes point out a typical shear failure, with cracks concentrated near the vertical interfaces. For the RB case, the cracks on the central walls are predominantly short and inclined, while the SB cases present long

and almost vertical cracks near the interface, especially the connection with steel trusses (SBT). The cracks on the flange walls of the stack bond specimens (SBT and SBS) are less severe and thick than the RB case, where there is larger force transference from the central web wall to the flange walls, due to the interpenetration of the blocks.

The RB specimens present a brittle failure, while the SB specimens show a tendency for ductile failure, provided by the steel connectors. This can be observed in Figures 5, 6 and 7 that shows the load-displacement diagrams for the three different types of specimens: RB, SBT and SBS, respectively. The plotted displacement corresponds to the vertical movement of the upper plate of the testing machine. The focus of the analysis is the after peak displacement, that is shorter for the RB specimens, with quick drops. Note that some curves for the SBS specimens present a yield threshold.

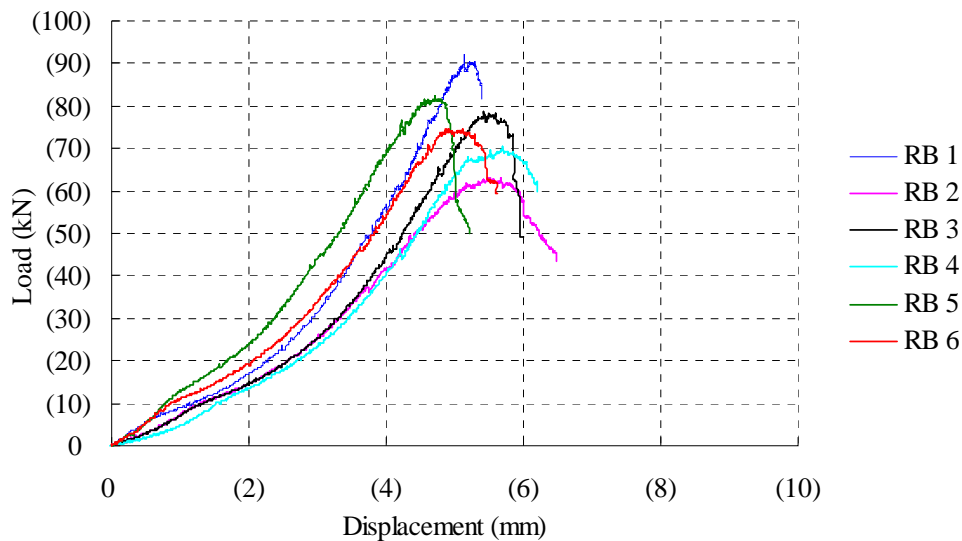

Figure 5: Diagram load-vertical displacement - RB specimens

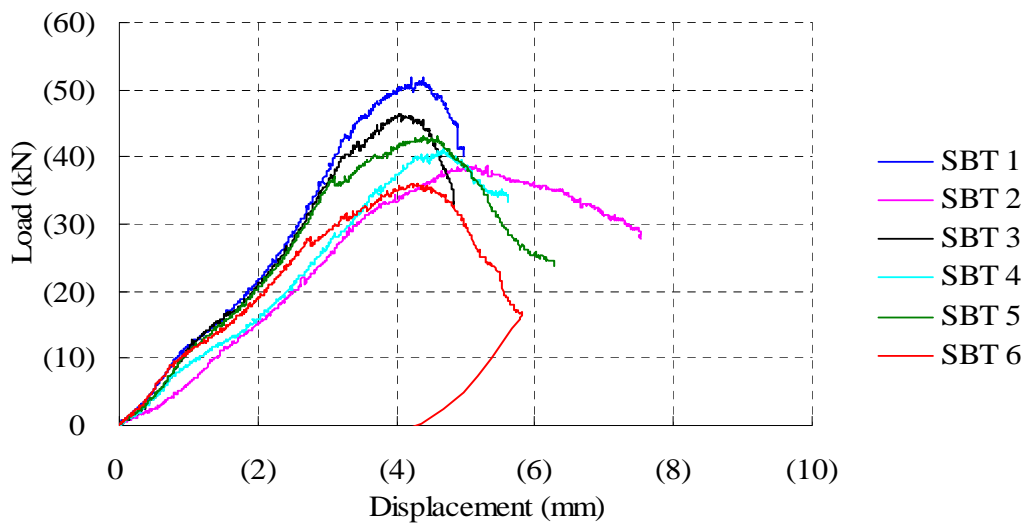

Figure 6: Diagram load-vertical displacement - SBT specimens

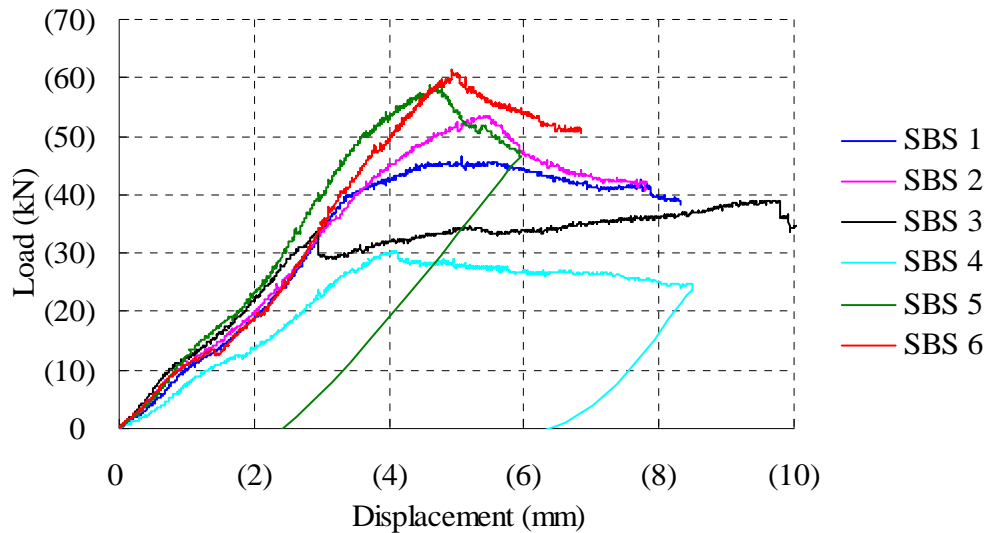

Figure 7: Diagram load-vertical displacement - SBS specimens

CONCLUSIONS

The present study shows that: the H-shaped specimen, supported only under the flanges, leads to a shear failure of the vertical interface, for all types of connections investigated in this experimental program. The shear strength at failure of the vertical interface of the stack bond specimens is roughly 60% of the corresponding value for the running bond connection. The two stack bond connections provide a similar shear strength of the vertical interface, with a 5% level of significance. The load at which the first crack appears is similar for the three different types of connections, with the same level of significance. The running bond specimens have a brittle failure, while the stack bond ones provide a tendency for ductile failure, especially the specimens with steel staple connectors.

ACKNOWLEDGMENTS

The authors gratefully acknowledge the support of FAPESP - São Paulo State Research Support Foundation and CNPq – National Council for Scientific and Technological Development.

REFERENCES

1. Capuzzo Neto, V. (2005) "Interaction of interconnected clay masonry walls subjected to vertical loads" PhD Thesis – University of São Paulo, 321p, São Carlos, São Paulo, Brazil.
2. Simundic, G. (1997) "Diaphragm walls" M.Sc. Dissertation, Newcastle, New South Wales, Australia.
3. Lissel, S.L., Shrive, N.G. and Page, A.W. (2000) "Shear in plain, bed joint reinforced and post-tensioned masonry" Canadian Journal Of Civil Engineering, v. 27-5. p. 1021-1030, Ottawa, Ontario, Canada.

4. Camacho, J.S., Ramalho, M.A. and Andolfato, R.P. (2001) "An experimental study of the interaction among walls submitted to vertical loads" 6th Australian Masonry Conference, 12-13 July 2001, Adelaide University, Adelaide, South Australia, Australia.
5. Silva, W.J. (2003) "Experimental study of the connections of clay blockwork walls under vertical loading" MSc Dissertation - São Paulo State University, 144p., Ilha Solteira, São Paulo, Brazil.
6. Bosiljkov, V., Simundic, G. and Page, A.W. (2004) "An analytical study of the composite behaviour of masonry geometric sections" 7th Australian Masonry Conference, 13-16 July 2004, The University of Newcastle, Newcastle, New South Wales, Australia.
7. Capuzzo Neto, V. (2000) "Theoretical and experimental study of the interaction of interconnected walls subjected to vertical loads. São Carlos", MSc Dissertation- University of São Paulo, 111p, São Carlos, São Paulo, Brazil.
8. Capuzzo Neto, V., Correa, M.R.S., and Ramalho, M.A. (2008) " Proposal of a test specimen to evaluate the shear strength of vertical interfaces of running bond masonry walls. Canadian Journal of Civil Engineering, v.35, p.567-573, Ottawa, Ontario, Canada.
9. Capuzzo Neto, V., Correa, M.R.S., and Ramalho, M.A., (2007) "Shear strength of vertical interfaces of intersecting walls" 10th North American Masonry Conference, The Masonry Society, Saint Louis, Missouri, USA.
10. Moreira, E.M., (2007) Experimental small-scale analysis of the connections between structural clay block work masonry walls submitted to vertical loads MSc - University of São Paulo, 147p, São Carlos, São Paulo, Brazil.