



EVALUATION OF HORIZONTAL COLLAPSE LOAD FOR A RIGID DOME SUPPORTED BY RADIAL MASONRY COLUMNS SUBJECTED TO OWN WEIGHT

C. Anselmi¹, E. De Rosa² and F. Galizia³

¹Associate Professor, Dipartimento di Costruzioni e Metodi Matematici in Architettura, Università Federico II, Naples, Italy, anselmi@unina.it

² Assistant Professor, Dipartimento di Costruzioni e Metodi Matematici in Architettura, Università Federico II, Naples, , Italy, ennio.derosa@unina.it

³ PhD, Università Federico II, Naples, Italy, fgalizia@unina.it

ABSTRACT

The aim of this work is to estimate through the static theorem of limit analysis the safety of a masonry dome -assumed as a single rigid block- supported by radial rigid masonry columns and subjected to their own weight and to increasing horizontal loads. The yield domain conditions for the quadrilateral sections of the columns are expressed in terms of the six stress resultants, on the assumption that masonry has unlimited compressive strength, an inability to sustain tension, sliding with dilatancy. The results obtained are very encouraging and show a good coherence with regard to the kinematic answer.

KEYWORDS: masonry domes, rigid blocks, limit analysis, yield domains, horizontal load multiplier, collapse mechanism.

INTRODUCTION

The problem of safeguard of historic masonry buildings that characterize most of the old European town centres and, particularly, that one concerning the preservation of the masonry domes, is of great interest at present. Many authors point out the particular importance of the limit analysis in estimating the safety of masonry structures, when they are modelled as discrete systems of rigid blocks.

In this work, as first approach to the problem of the safety of more complex structures subjected to horizontal loads, we propose an extension and a generalization of a method already adopted in previous works with regard to simpler load conditions or structural typologies [1], [2], [3], [4]. This method is applied now to evaluate horizontal loads multiplier and collapse mechanism of a dome supported by radial masonry columns having quadrilateral section, subjected to own weight and to horizontal increasing loads. We, as a preliminary stage to the domes' analysis, assume like "rigid blocks" the dome (as a result of a hooping system) and also the columns which are supposed to be resting on underlying fixed structures.

The solution is obtained through the static theorem of limit analysis following these assumptions: an inability to sustain tension as regards the contact interfaces -namely at the bottom and at the top of the columns-an unlimited compressive strength at the interfaces and a provision for the blocks to slide with dilatancy. The results obtained are very encouraging and show a good coherence with regard to the kinematic answer.

THE EQUILIBRIUM CONDITIONS

The equilibrium conditions regard the dome and the columns below as single rigid blocks. The six contact forces N , T_r , T_s , M_t , M_r , M_s on the interfaces, are supposed to be applied at the centroid of each interface and refer to a local Cartesian axes n , r , s (Figure 1).

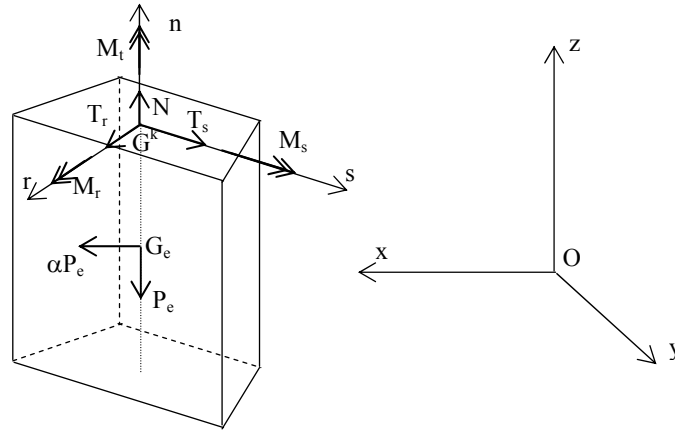

Figure 1: Contact forces on the generic interface; dead and live loads on the centroid block

The dome and columns are subjected to the six contact forces and to the dead P_e (the self weight of the block) load and to the live increasing horizontal load(s) αP_e - all parallel to x -axis - (α being a multiplier of self weight), both applied to the G_e centroid of the block. The six equilibrium equations of a generic "e" block can be expressed briefly by:

$$\mathbf{A}^e \mathbf{X}^e + \mathbf{F}_v^e + \alpha \mathbf{F}_0^e = \mathbf{0} \quad (1)$$

where, n_c being is the number of columns, \mathbf{A}^e is a $(6 \times 6n_c)$ or (6×12) matrix for the dome and generic column respectively, \mathbf{X}^e is the vector of the all unknown stress resultants on the generic block, \mathbf{F}_v^e is the vector of the dead loads and \mathbf{F}_0^e is the vector of the live loads, increasing by the multiplier α .

YIELD DOMAIN FOR THE GENERIC INTERFACE

The stress resultants on the interfaces have to respect the yield domains of the material for rocking (Figure 2) and sliding (Figure 3).

With reference to a quadrilateral section (Figure 4), as a coherent kinematic mechanism needs the rotation on an axis coincident with one of four sides of a section, for the N-M yield domain we imposed four conditions:

$$d_i N + M_i \leq 0 \quad (2)$$

with d_i the distance between G (Figure 4a) and the generic side "i" ($i=1, 2, 3, 4$) and $M_i = \mathbf{M} \cdot \mathbf{k}_i$, $\mathbf{M} = M_r \mathbf{k}_r + M_s \mathbf{k}_s$ being the Cartesian expression of the moment (Figure 4b). Therefore $\tan\psi$ in Figure 2 coincides with the generic distance d_i . We notice that the yield domain obtained in this way is coincident with that proposed through a different formulation by other authors [5].

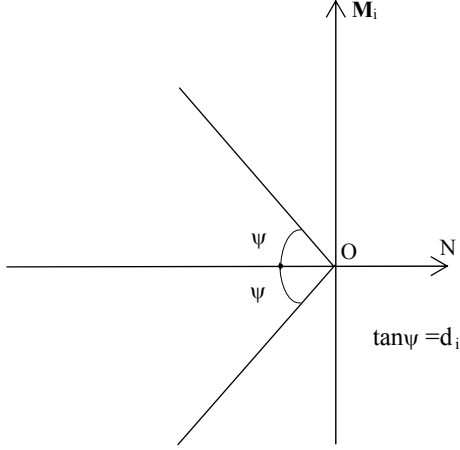

Figure 2: Rocking yield domain

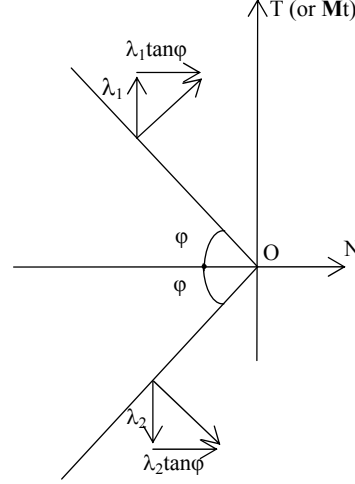

Figure 3: Sliding yield domain

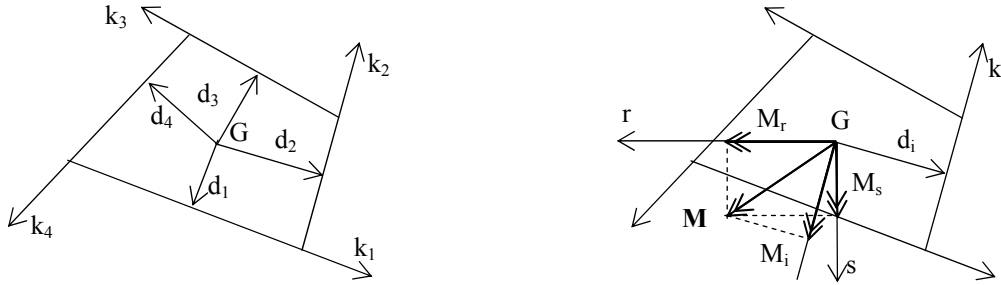

Figure 4: Quadrilateral section: a) geometrical aspect; b) mechanical aspect

In this first approach, the cone with axis coinciding with the N-axis that defines the N-T yield domain, has been opportunely replaced by a piecewise linear yield domain having four sides. Therefore we impose four conditions making reference to the Cartesian components T_r and T_s (Figure 1) of \mathbf{T} , being $\mathbf{T} = T_r \mathbf{k}_r + T_s \mathbf{k}_s$:

$$\tan\phi_0 N \pm T_r \leq 0 \tag{3}$$

$$\tan\phi_0 N \pm T_s \leq 0 \tag{4}$$

Thus, in Figure 3, T coincides with the generic component T_r or T_s whereas ϕ coincides with the angle of friction ϕ_0 .

For the N- M_i yield domain, by analogy with other authors [6], we have considered a circular section equivalent having radius R equal to the mean of d_i distances of Figure 4a:

$$R = (1/4) (d_1+d_2+d_3+d_4) \quad (5)$$

Therefore we impose two conditions:

$$(2/3)R \tan \varphi_0 N \pm M_t \leq 0 \quad (6)$$

where in Figure 3, $\tan \varphi = (2/3)R \tan \varphi_0$.

In the matrix form the conditions expressed by the (2), (3), (4) and (6) become:

$$\begin{bmatrix} d_1 & 0 & 0 & 0 & (\mathbf{k}_r \cdot \mathbf{k}_1) & (\mathbf{k}_s \cdot \mathbf{k}_1) \\ d_2 & 0 & 0 & 0 & (\mathbf{k}_r \cdot \mathbf{k}_2) & (\mathbf{k}_s \cdot \mathbf{k}_2) \\ d_3 & 0 & 0 & 0 & (\mathbf{k}_r \cdot \mathbf{k}_3) & (\mathbf{k}_s \cdot \mathbf{k}_3) \\ d_4 & 0 & 0 & 0 & (\mathbf{k}_r \cdot \mathbf{k}_4) & (\mathbf{k}_s \cdot \mathbf{k}_4) \\ \tan \varphi_0 & 1 & 0 & 0 & 0 & 0 \\ \tan \varphi_0 & -1 & 0 & 0 & 0 & 0 \\ \tan \varphi_0 & 0 & 1 & 0 & 0 & 0 \\ \tan \varphi_0 & 0 & -1 & 0 & 0 & 0 \\ \frac{2}{3}R \tan \varphi_0 & 0 & 0 & 1 & 0 & 0 \\ \frac{2}{3}R \tan \varphi_0 & 0 & 0 & -1 & 0 & 0 \end{bmatrix} \cdot \begin{bmatrix} N \\ T_r \\ T_s \\ M_t \\ M_r \\ M_s \end{bmatrix} \leq \begin{bmatrix} 0 \\ 0 \\ 0 \\ 0 \\ 0 \\ 0 \\ 0 \\ 0 \\ 0 \\ 0 \end{bmatrix} \quad (7)$$

or:

$$\mathbf{Y}^f = \mathbf{D}^f \mathbf{X}^f \leq \mathbf{0} \quad (8)$$

where \mathbf{D}^f is a (10x6) matrix and \mathbf{X}^f is the vector of the unknown stress resultants on the generic section "f", while \mathbf{k}_1 , \mathbf{k}_2 , \mathbf{k}_3 and \mathbf{k}_4 are, in an orderly way, the side unit vectors of a generic quadrilateral section (Figure 4a).

GOVERNING CONDITIONS

If n and m are the number of rigid blocks and of interfaces, the equilibrium conditions are:

$$\mathbf{A} \mathbf{X} + \mathbf{F}_v + \alpha \mathbf{F}_o = \mathbf{0} \quad (9)$$

and the yield domain's conditions are:

$$\mathbf{Y} = \mathbf{D} \mathbf{X} \leq \mathbf{0} \quad (10)$$

where \mathbf{A} is a (6n x 6m) matrix, \mathbf{X} is a 6m-vector, \mathbf{F}_v and \mathbf{F}_o are 6n-vectors, α is the unknown collapse multiplier, \mathbf{D} is a (10m x 6m) matrix. Consequently, the problem can be formulated in the following manner:

maximize α
subject to:

$$\mathbf{A} \mathbf{X} + \mathbf{F}_v + \alpha \mathbf{F}_o = \mathbf{0} \quad (11)$$

$$\mathbf{Y} = \mathbf{D} \mathbf{X} \leq 0 \quad (12)$$

$$\alpha \geq 0 \quad (13)$$

THE EVALUATION OF COLLAPSE MECHANISM

Once the multiplier α has been calculated we can pursue the kinematic problem taking into account the following conditions:

$$\mathbf{A}^T \mathbf{u} = \Delta \quad (14)$$

and of the flow rule:

$$\Delta = \mathbf{D}^T \lambda \quad (15)$$

\mathbf{u} being the vector of the degrees of freedom (six for every block), Δ the vector which collects the displacements between the interfaces (six for every interface) and λ the vector of the generalized strain rates associated to the yield conditions (ten for every interface).

APPLICATIONS

We have analyzed a hemispheric dome with the following geometric characteristics: $R_e = 6\text{m}$, $R_i = 5\text{m}$ (and then thickness $s = 1\text{m}$), R_e and R_i being extrados radius and intrados radius. It is supported by eight radial rigid masonry columns having a symmetric trapezium shaped section (Figure 5), with a height $h = s \cos(\theta_c/2)$, a smaller base $b_i = 2 R_i \sin(\theta_c/2)$ and a greater base $b_e = 2 R_e \sin(\theta_c/2)$.

In a general formulation the amplitude θ_c can be defined by $k_c(2\pi/n_c)$, with k_c a positive coefficient < 1 and n_c the number of columns, while the amplitude of openings between two columns adjoining is defined by the angle $\theta_o = k_o(2\pi/n_c)$, being $k_o = 1 - k_c$.

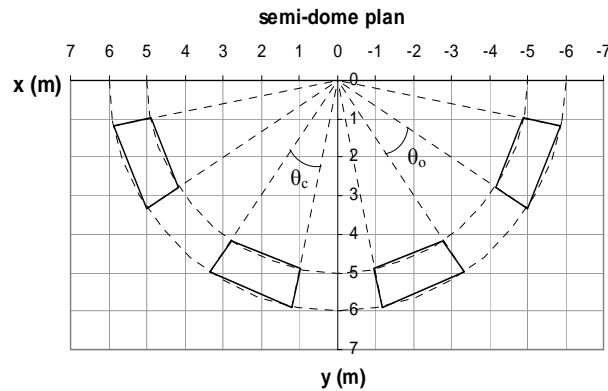

Figure 5: Semi-dome plan

In Table 1 are showed the values of collapse loads multiplier α , varying both the height H and the coefficient k_c , having assumed as friction coefficient $\tan\phi_0=0.75$.

In Table 2 are showed the values of α , for assigned values of $\tan\phi_0$ included between 0.5 and 0.8, for a fixed height $H = 6m$ of columns. We can observe that, for a fixed k_c , varying $\tan\phi_0$ there isn't much difference of the values of α .

Table 1: $\alpha - H - k_c$ relationships

$k_c \backslash H(m)$	0.3	0.4	0.5	0.6	0.7
1	0.975139	0.973648	0.972221	0.970863	0.96958
2	0.783591	0.873526	0.87031	0.866886	0.863256
3	0.522559	0.647213	0.768817	0.794008	0.789265
4	0.3918	0.484651	0.574293	0.66086	0.737882
5	0.313261	0.387555	0.457758	0.526208	0.591456
6	0.260886	0.322598	0.381314	0.43664	0.490368
7	0.223471	0.276142	0.326409	0.373577	0.418357
8	0.195411	0.241283	0.285117	0.326503	0.364684
9	0.173588	0.214169	0.252961	0.289712	0.324046
10	0.156131	0.19248	0.227226	0.260211	0.2912

Table 2: $\alpha - \tan\phi_0$ relationships, for $H=6m$

$k_c \backslash \tan \phi_0$	0.3	0.4	0.5	0.6	0.7
0.5	0.260645	0.320947	0.378503	0.433563	0.482711
0.55	0.260722	0.321530	0.378939	0.434344	0.486710
0.6	0.260779	0.321925	0.379319	0.435027	0.487796
0.65	0.260823	0.322212	0.379812	0.435628	0.488754
0.7	0.260858	0.322428	0.380710	0.436162	0.489606
0.75	0.260886	0.322598	0.381314	0.436640	0.490368
0.8	0.260909	0.322735	0.381780	0.437010	0.491053

In Figures 6 and 7, with reference to Table 1, $\alpha - H$ curves (for different values of k_c) are drawn and $\alpha - k_c$ curves (for different values of H) are drawn.

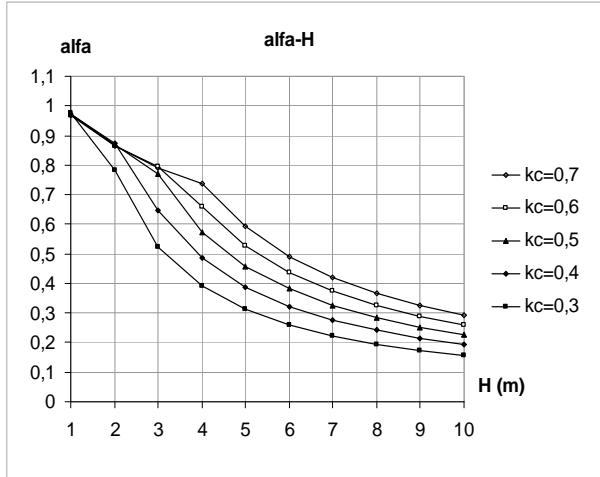

Figure 6: $\alpha - H$ curves

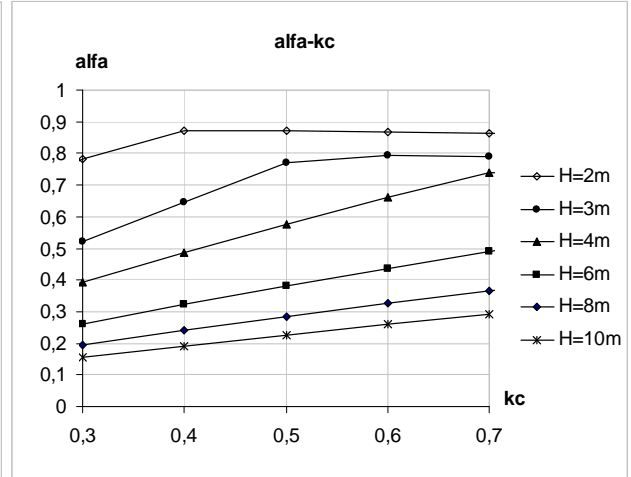

Figure 7: $\alpha - k_c$ curves

In Figure 8 the collapse mechanism corresponding to a dome where the height of the columns is $H = 6\text{m}$ and $k_c = 0.5$ is drawn. The mechanism obtained -essentially a rocking mechanism of the columns- is that expected, as Figure 8b also shows.

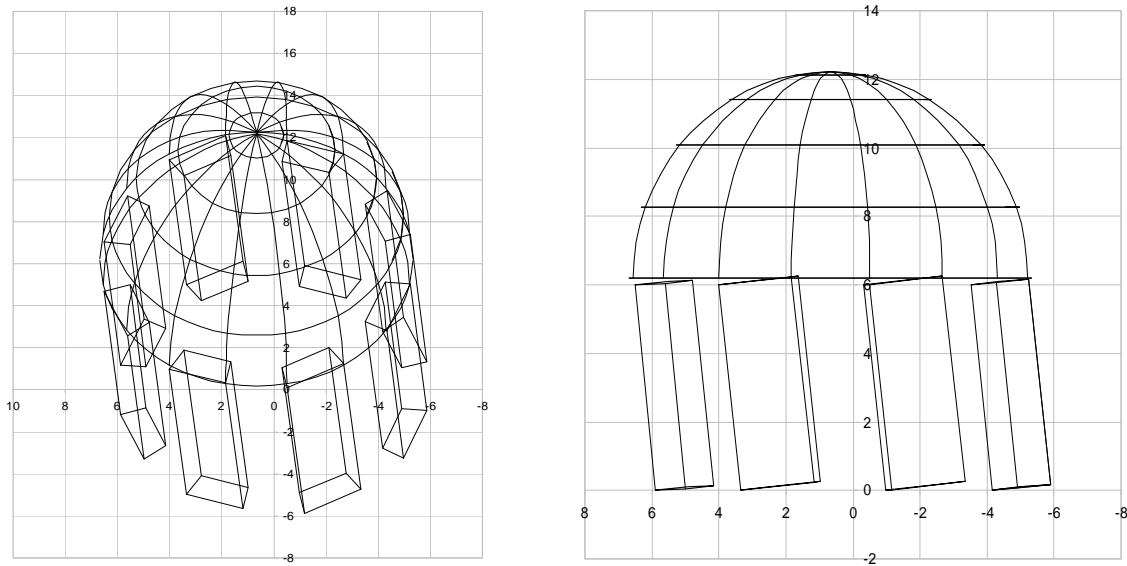

Figure 8: Collapse mechanism a) axonometric view; b) front view

CONCLUSIONS

The behaviour of masonry domes subjected to seismic loads still does not seem to have been broached in current literature. As first approach to the problem of the evaluation of the safety of these complex structures, in this study we have calculated the horizontal loads multipliers of a dome taken as a single rigid dome, supported by radial rigid masonry columns having a quadrilateral section. Both the dome and the columns are subjected to their own weight and to horizontal increasing loads. The horizontal loads multipliers have been obtained through the

static theorem of limit analysis, on the assumption of an unlimited compressive strength, an inability to sustain tension and sliding with dilatancy.

Even if we have found neither experimental nor theoretical results to make a comparison, our procedure, although considering a simple model and very simple yield conditions, has shown good coherence with regard to kinematic answer and has encouraged us to extend this methodology to more complex problems like masonry domes, with and without drum and lantern, modelled as discrete systems of rigid blocks and subjected to horizontal loads.

REFERENCES

1. Anselmi, C., De Rosa E., and Fino L. (2004) "Limit analysis of masonry structures" 4th International Seminar on Structural Analysis of Historical Constructions, Padova, Italy.
2. Anselmi, C., De Rosa E., and Fino L. (2005) "Evaluation of collapse load for masonry walls" 10th Canadian Masonry Symposium, Banff, Alberta, Canada.
3. Anselmi, C., De Rosa E., and Fino L. (2006) "Evaluation of static collapse multiplier for masonry walls subjected to out-of-plane loading" 7th International Masonry Conference, London, on CD-ROM.
4. Anselmi, C., De Rosa E., Galizia, F. and Maniello, D. (2006) "Evaluation of the safety coefficient of axi-symmetric masonry domes with drum and lantern having variable profile and carrying their own weight" 7th International Masonry Conference, London, on CD-ROM.
5. Orduña, A. and Lourenço, P. (2005) "Three-dimensional limit analysis of rigid blocks assemblages. Part I: Torsion failure on frictional interfaces and limit analysis formulation" *Int.J.Solids Structures*, in press, doi:10.1016/j.ijsolstr.2005.02.010.
6. Baggio, C. and Trovalusci, P. (1998) "Limit analysis for no-tension and frictional three-dimensional discrete systems" *Mechanics of Structures and Machines*. 26 (3): 287-304.
7. Ferris, M.C. and Tin-Loi, F. (1999) "Limit Analysis of Frictional Block assemblies as a Mathematical Program with Complementary Constraints" *International Journal of Mechanical Sciences* (43): 209-224.
8. Franciosi, V. (1984) "L'attrito nel calcolo a rottura delle murature" *Giornale del Genio Civile*: 215-234.
9. Gilbert, M. and Melbourne, C. (1994) "Rigid-block Analysis of Masonry Structures" *The Structural Engineer* (72) 21: 356-361.
10. Heyman, J. (1966) "The Stone Skeleton" *International Journal Solids Structures* (2): 249-279.
11. Heyman, J. (1968) "The Safety of Masonry Arches" *International Journal Mechanical Sciences* (11): 363-385.
12. Casapulla, C. and D'Ayala, D., (2001) "Lower-bound approach to the limit analysis of 3D vaulted block masonry structures" Hughes, T.G., Pande, G.N. (Eds.), *Computer Methods in Structural Masonry*, vol. 5, Rome, Italy, pp. 177-183.
13. Restrepo-Vélez, L.F. and Magenes, G., (2005) "A mechanics based methodology for the evaluation of the seismic risk of unreinforced masonry buildings" *Research Report no. ROSE-2005/05*, IUSS Press, Pavia.