



A STUDY OF THE STRUCTURAL BEHAVIOR OF MASONRY PRISMS AND WALLETES BUILT WITH A NEW TYPE OF CONCRETE BLOCK

A. Oliveira¹, J. Casali² and L. R. Prudêncio Jr.³

¹ Federal Center of Technological Education of Santa Catarina, DCC, Florianópolis/SC, Brazil,
alexandre@cefetsc.edu.br

² Federal University of Santa Catarina, Civil Engineering Department, Florianópolis/SC, Brazil,
jucasali@hotmail.com

³ Federal University of Santa Catarina, Civil Engineering Department, Florianópolis/SC, Brazil,
prudenciouk@hotmail.com

ABSTRACT

In southern Brazil, one type of hollow concrete block is typically employed in structural masonry constructions. Its dimensions are 140 x 190 x 390 mm (width x height x length), which is not a modular size (its nominal length [400 mm] is not a multiple of its nominal thickness [150 mm]). What is more, the block's geometry does not allow superimposition with perfect alignment of its cores; this produces stress concentration in structural masonry walls. In this context, this work proposes a new type of hollow concrete block (140x190x440 mm), which does allow full alignment of the cores. The behaviour of masonry prisms and wallettes was evaluated, for both types of blocks, using finite element (FE) modelling. Linear elastic FE analyses were carried out by modelling the prisms and wallettes with a fine mesh of solid elements, and by taking into account the positions of the cores as well as the mortar bedding pattern (face-shell bedding and full mortar bedding). The results of the numerical analyses show that, with face-shell bedding, the levels of stress in the prisms and wallettes are very similar for the two types of blocks. However, with full mortar bedding, while the stress levels in the prisms are also very similar for the two types of blocks, the new type of concrete block has the best structural performance in the wallettes, with lower levels of stress, due to a better alignment of the cores allowed by this new type of concrete block.

KEYWORDS: concrete blocks, finite element, linear elastic, prisms, wallettes, face shell bedding and full mortar bedding.

INTRODUCTION

In the past 10 years, structural masonry has been gaining importance in southern Brazil, with use of 140x 190x 390 mm (width x height x length) concrete blocks being particularly significant. This type of block is not perfectly modular (its length is not a multiple of its thickness), thus requiring that special blocks (140x 190x 340 mm and 140x 190x 540 mm) be utilized for running bonds in "L" or "T" intersections. Moreover, the block's geometry does not allow perfect

alignment of its cores and webs (see Figure 1); this produces stress concentration in structural masonry walls [1].

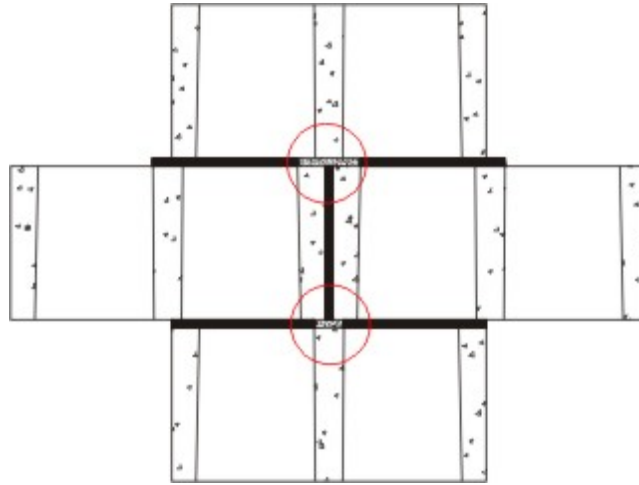

Figure 1: Diagram showing misalignment of block webs and cores in successive courses of a wall constructed with 140x 190x 390 mm blocks

In this context, a new type of hollow concrete block is proposed. It allows full alignment of the cores in order to reduce stress concentration in the block's webs, thus improving structural performance when employing such blocks in structural masonry walls. The dimensions of this new type of block are 140x 190x 440 mm (width x height x length).

Several authors have conducted experimental testing and numerical analyses on the performance of blocks in hollow masonry prisms with full and face-shell mortar bedding, [2, 3, 4, 5, 6]. However, given that most of their studies were only carried out with masonry prisms, they were unable to evaluate the effect of block web misalignment. Mata's investigation [2] was the only exception, having also assessed the performance of hollow blocks in wallettes (and not just in prisms) constructed using varying mortar bedding patterns, thus showing the effect of web misalignment, with numerical analysis results that were compared to those of experimental trials.

With this in mind, in order to evaluate performance of the block geometry proposed in the present study, finite element analyses were conducted for 140x 190x 390 mm blocks, as well as for 140x 190x 440 mm blocks, in three-block prisms and wallettes with full and face-shell bedding.

NUMERICAL MODELLING

Linear elastic FE analyses were carried out using isoparametric solid elements with eight nodes, by means of the SAP2000® software [7]. The block types, the structural elements that were modelled, and the properties of the materials considered in the numerical analyses are presented in detail below.

A performance evaluation was conducted comparing the type of hollow block commonly employed in southern Brazil (140x 190x 390¹ mm) to the type of block proposed here. Figures 2 and 3 respectively detail the geometry of the 140x 190x 390 mm and 140x 190x 440 mm blocks used in the numerical analyses and models of the prisms and wallettes.

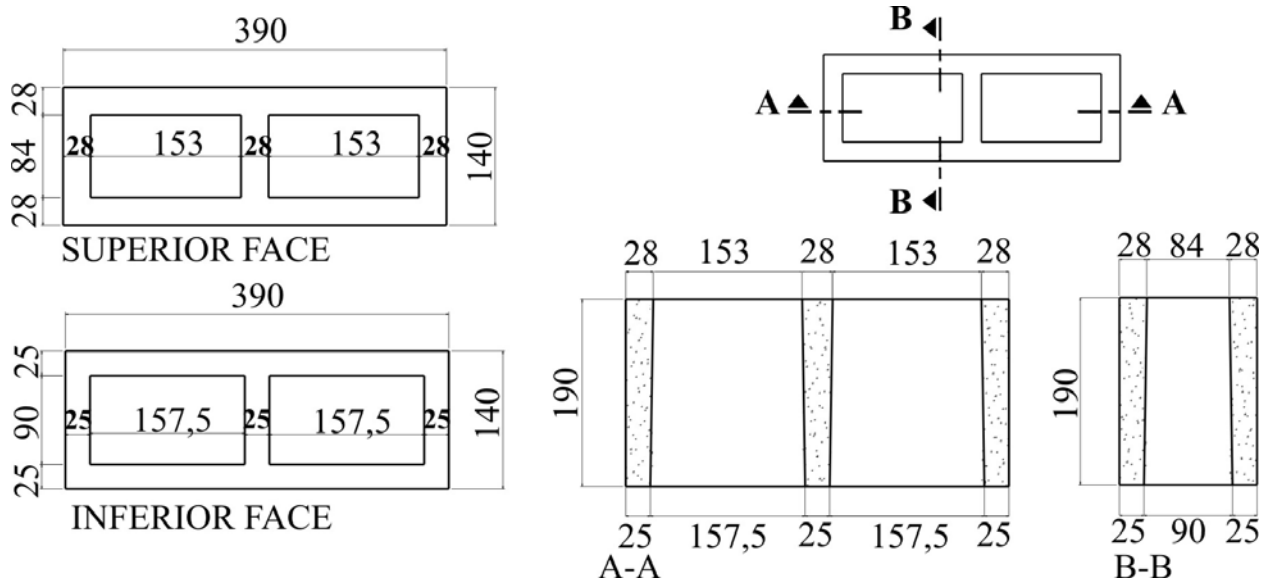

Figure 2: Geometry of the 140x 190x 390 mm block (dimensions in mm)

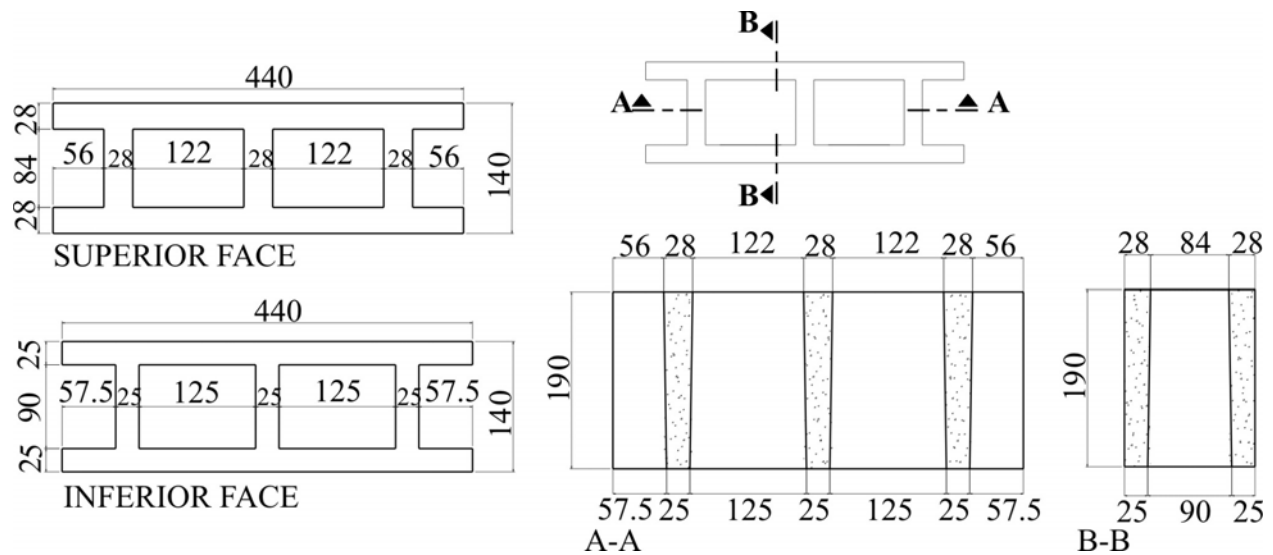

Figure 3: Geometry of the 140x 190x 440 mm (dimensions in mm)

It is worth noting that, for both types of blocks, tapering was 3 mm for each of the face shells and external webs, and 0.15 mm for the internal webs for both sides. The same web dimensions and

¹ This geometry meets the NBR 6136 - Brazilian standard [8].

tapering as in Steil's work [6] were chosen for the current analyses since Steil found that this particular geometry had an influence on structural performance in masonry prisms.

For more details concerning potential use of the proposed block (140x 190x 440 mm) in construction projects, see Torresani [9].

In this study 1.19 x 0.99² m wallettes and three-block high prisms (both shown in Figure 4) were selected for modelling and numerical analysis.

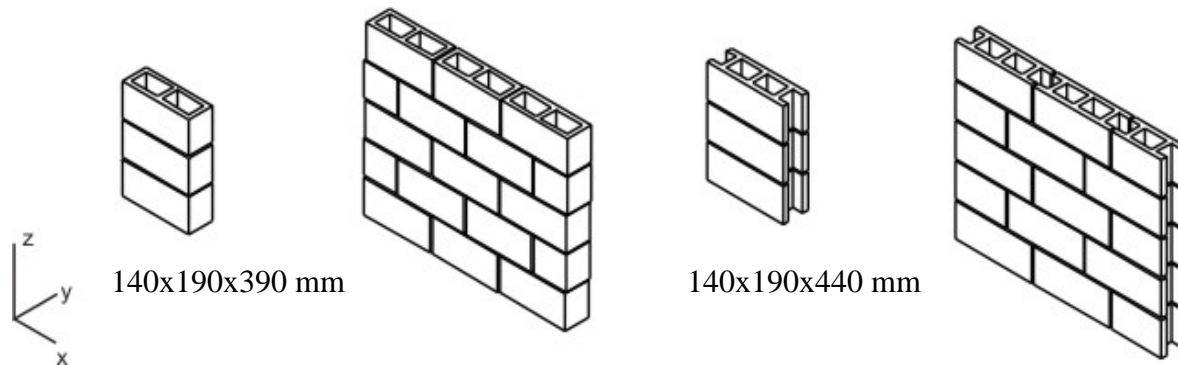

Figure 4: Models of the prisms and wallettes built with 140x 190x 390 mm and 140x 190x 440 mm blocks

Load was applied on top of the prisms and wallettes (in a downwards direction). For this reason, all of the nodes belonging to the upper surface of the prisms and wallettes were confined in the x and y directions, which made them free to move along the z axis (for load application). Moreover, the "constrain" command was used on these nodes so that their movement along the z axis would be characterized as rigid body motion, thus simulating a rigid platen with fairly close approximation to that which occurs in an experimental compression test (note that this has no affect on the central area of the wallets and prisms, where the greatest levels of tensile stress occur). Nodes belonging to the base of the prisms and wallettes were confined with respect to all three axes (x, y and z) in order to simulate confinement by the platen.

Both the prisms and wallettes were modelled taking into account use of full and partial mortar bedding. For the case of full bedding, the load was applied on the entire top surface (load applied against 100% of the area). For the case of partial bedding, however, the load was only applied against the face shell portions of the top surface, simulating parallel mortar beds, as shown in Figure 5.

² Length x height.

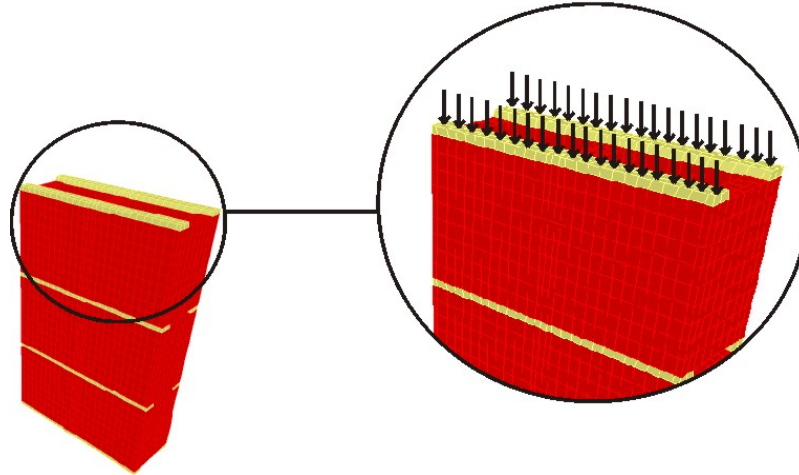

Figure 5: Face shell mortar beds and load application when using partial mortar bedding

MATERIALS

As mentioned, linear elastic FE analyses were carried out. It was assumed that the properties of the relevant materials were characterized by the values contained in Table 1, also used by Mata [2]. The dimensions of the solid elements employed in the mesh were 9 x 20 x 16 mm and 14 x 20 x 19 mm. These dimensions were sufficiently small given that they allowed differences in tensile stress to be found when comparing between the two types of blocks.

The load used in the numerical models was limited to 50% of the failure load estimated for a typical wall so as to make certain that, in a real structure, the simulated materials would behave linear-elastically. A prism/unit ratio of 65% was employed to determine the failure load (65% is the smallest figure that has been obtained for this ratio in studies carried out in Brazil [2] [6]). Accordingly, the compressive stress used in the numerical models was calculated as follows:

$$\text{Load simulated in numerical models} = 50\% \cdot F_m = 0.5 \cdot 0.65 \cdot 11.5 = 3.74 \text{ MPa} \quad (1)$$

Table 1: Properties of the materials used in the numerical analyses

	Compressive strength (MPa)	Modulus of elasticity (MPa)	Poisson's ratio (ν)
Hollow block	11.5*	18990.5**	0.17
Mortar	5.0	4224.5	0.24

* Block compressive strength evaluated using the net area

** Experimental value obtained for similar blocks in Mohamed [10], a study conducted in Brazil.

RESULTS AND DISCUSSION

Figures 6 to 9 represent the results of the numerical analyses for prism and wallette models simulating full mortar bedding with 140x 190x 390 mm and 140x 190x 440 mm blocks. Since wallette and prism failure occurs due to tensile stress, our analysis of results focuses on the maximum tensile stress obtained with the numerical models.

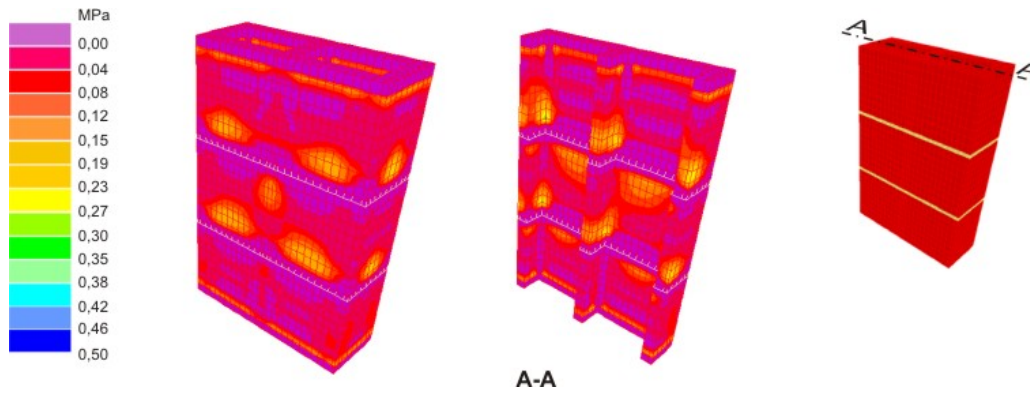

Figure 6: Maximum tensile stress obtained for prism models with 140x 190x 390 mm blocks and full mortar bedding

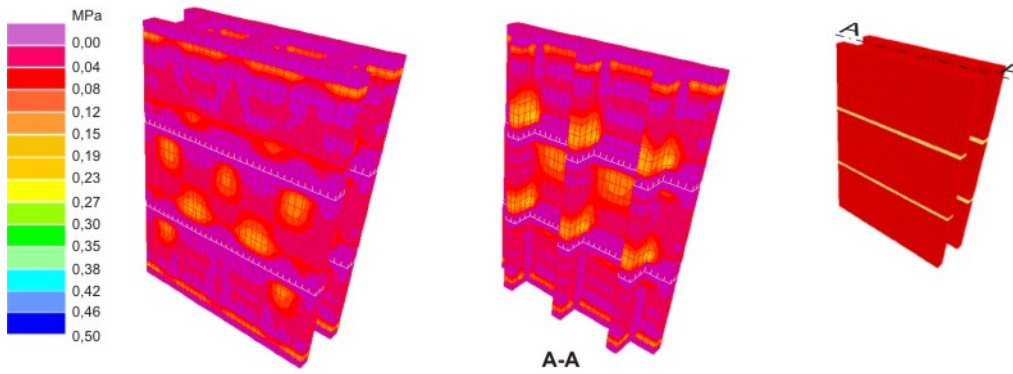

Figure 7: Maximum tensile stress obtained for prism models with 140x 190x 440 mm blocks and full mortar bedding

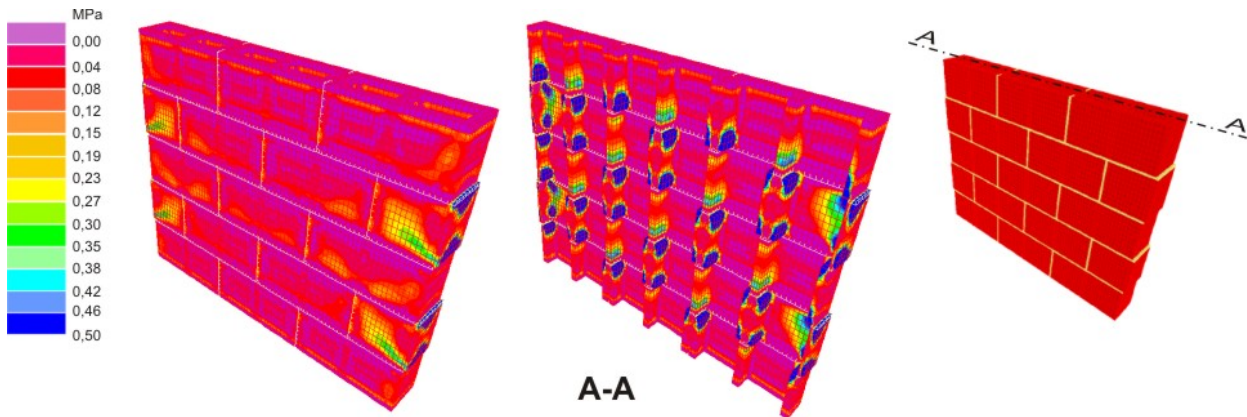

Figure 8: Maximum tensile stress obtained for wallette models with 140x 190x 390 mm blocks and full mortar bedding

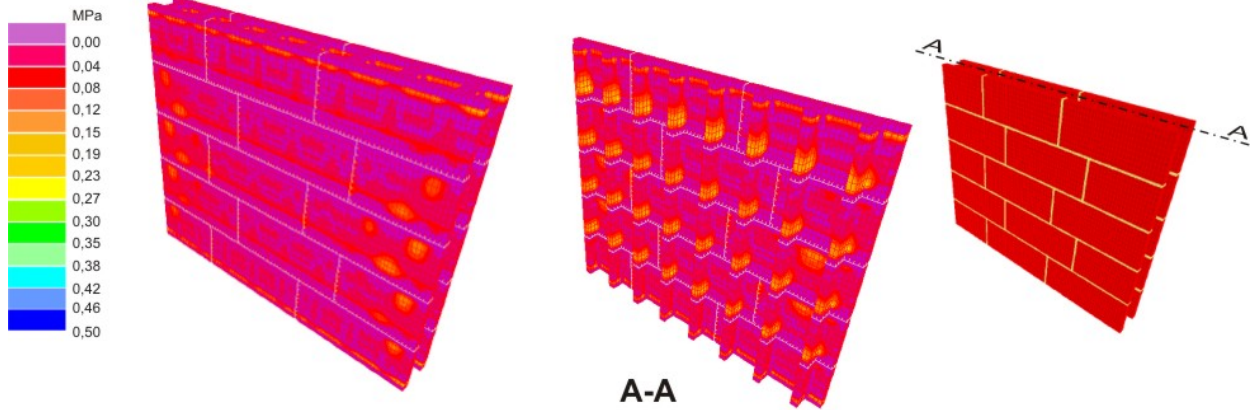

Figure 9: Maximum tensile stress obtained for wallette models with 140x 190x 440 mm blocks and full mortar bedding

Figures 10 to 13 represent the results of the numerical analyses for prism and wallette models simulating partial mortar bedding with 140x 190x 390 mm and 140x 190x 440 mm blocks.

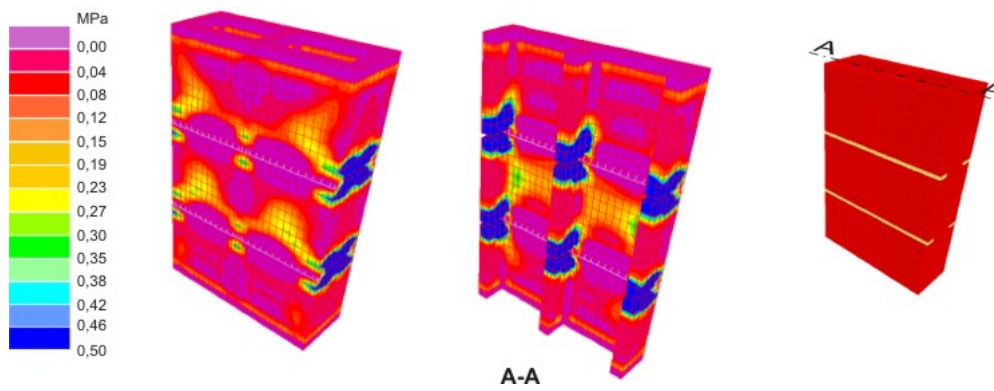

Figure 10: Maximum tensile stress obtained for prism models with 140x 190x 390 mm blocks and face-shell bedding

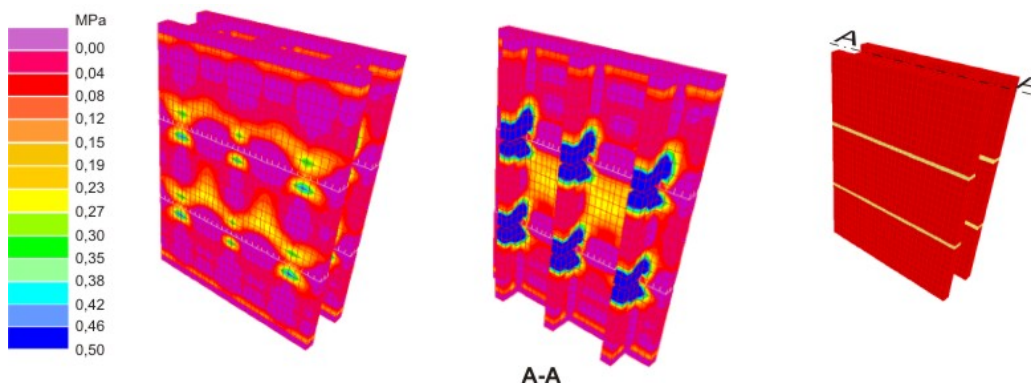

Figure 11: Maximum tensile stress obtained for prism models with 140x 190x 440 mm blocks and face-shell bedding

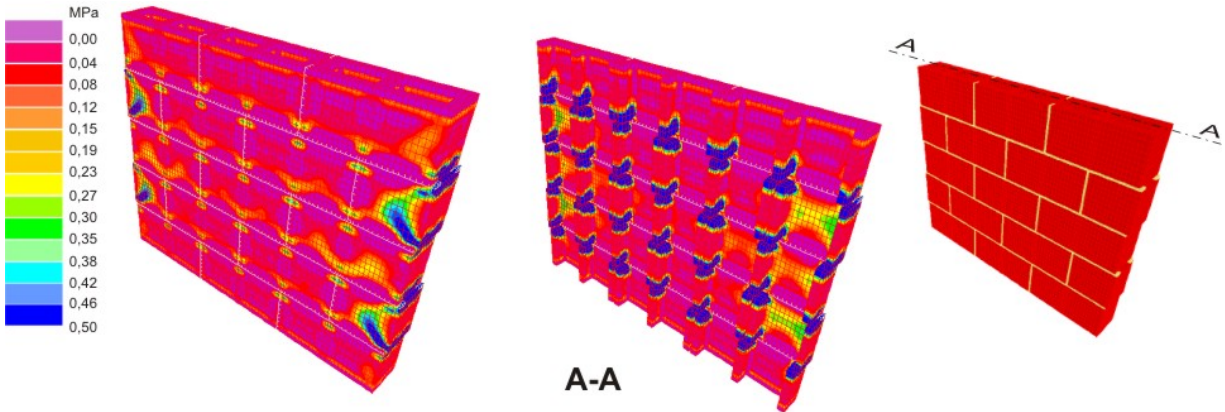

Figure 12: Maximum tensile stress obtained for wallette models with 140x 190x 390 mm blocks and face-shell bedding



Figura 13: Maximum tensile stress obtained for wallette models with 140x 190x 440 mm blocks and face-shell bedding

Analysis of the linear elastic FE results for maximum tensile stress obtained through the finite element method (Figures 6 to 13) reveals that both the prisms and wallettes modelled with face shell bedding had more elevated tensile stress levels than those modelled with full mortar bedding. All the models simulating face shell bedding yielded similar maximum tensile stress levels, in the order of 3.3 MPa, as shown in Table 2. In other words, for models reproducing face shell bedding, neither the type of block (whether it be 140x 190x 390 mm or 140x 190x 440 mm) nor the type of structure in which it was used (prism or wallette) had a significant effect on the stress pattern obtained by numerical analysis. In all such cases, stress concentration occurred in the upper and lower parts of the webs, due to a lack of support for the webs caused by the absence of joints in these areas.

Table 2: Summary of tensile and compressive stress values obtained from the FE analyses

Mortar bedding	Type of masonry	Type of block (dimensions in mm)	Maximum stress (MPa)		
			σ_x (tension)	σ_y (tension)	σ_z (compression)
Full	Prisms	140x190x 390	0.23	0.20	-4.30
		140x 190x 440	0.20	0.18	-4.70
	Wallettes	140x190x 390	1.70	0.40	-4.60
		140x 190x 440	0.27	0.16	-4.20
Face shell	Prisms	140x190x 390	3.30	0.30	-5.40
		140x 190x 440	3.00	0.37	-5.40
	Wallettes	140x190x 390	3.30	0.60	-5.20
		140x 190x 440	3.00	0.34	-5.10

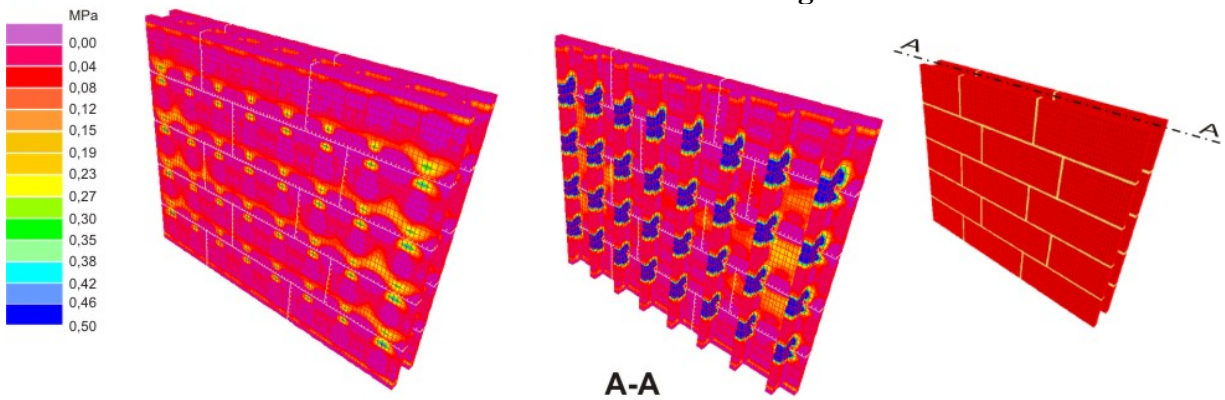
With regard to the prism models, and more specifically those simulating full mortar bedding, there were no significant variations in the maximum tensile stress distribution patterns between models with 140x 190x 390 mm blocks (Figure 6) and those with 140x 190x 440 mm blocks (Figure 7), given that all of the webs were perfectly supported in both cases. However, the wallette modelled with 140x 190x 390 mm blocks and full mortar bedding (Figure 8) yielded tensile stress concentration in the upper and lower parts of the webs. These levels of tensile stress were significantly higher (1.70 MPa – Table 2) than those that occurred in the wallettes modelled with 140x 190x 440 mm blocks and full mortar bedding (0.27 MPa - Figure 9 and Table 2).

CONCLUSION

The results presented indicate that, compared to 140x 190x 390 mm blocks, the 140x 190x 440 mm hollow blocks proposed here have great potential with respect to structural performance in walls built with full mortar bedding. These numerical analysis results will later be compared to experimental results. Indeed, the current study is part of a greater project for which blocks with the proposed geometry (140x 190x 440 mm) have already been produced, in full scale, in order to build prisms, wallettes and walls (measuring 2.60 m in height) for laboratory studies, the results of which will be published shortly. Using the unit proposed here would probably help reduce stress concentration (decreasing tensile stress levels and increasing load capacity) and reduce the amount of cement required to manufacture concrete blocks, for a given level of stress.

REFERENCES

1. Page, A. W., Shrive, N. G. (1989) "A critical assessment of compressive tests for hollow block masonry" *Masonry International*, Vol. 2, pp. 64-70.
2. Mata, R. C. (2006) "Influence of mortar bedding on the compressive strength of concrete masonry wallets and prisms". Msc. Dissertation (Civil Engineering Program – PPGEC) – Federal University of Santa Catarina, Florianópolis. 180p. (*in Portuguese*).

3. Hamid, A., Chucwunenye, A. (1986) “The compression behavior of concrete masonry prisms”, Journal of the Structural Division, Proceedings of the ASCE, Vol. 112, No. 3, pp. 605-614.
4. Ganesan, T.P., Ramamurthy, K. (1992) “Behavior of concrete hollow-block masonry prisms under axial compression”. Journal of Structural Engineering, ASCE, Vol. 118, No. 7, pp. 1751-1769.
5. Shrive, N.B. (1982) “The failure mechanism of face shell bedded ungrouted and unreinforced Masonry”. International Journal of Masonry Construction, Vol. 2, No. 3, pp.115-128.
6. Steil, R. O. (2003) ‘The effect of block geometry and mortar type in the compression behavior of ungrouted concrete masonry prisms’. Msc. Dissertation (Civil Engineering Program- PPGEC) – Federal University of Santa Catarina, Florianópolis, 2003, 161p. (*in Portuguese*).
7. SAP2000 – Computers and Structures, Inc. Version 10.0 (2006).
8. Association Brazilian of Standards (NBR) (1994) “Hollow concrete block for concrete masonry - requirements”. NBR 6136. Rio de Janeiro.
9. Torresani, J. H. (2006) “Proposta de nova tipologia de blocos de concreto para alvenaria estrutural e contribuição para fabricação de blocos em escala reduzida”. Graduation (Civil Engineering Department- ECV) – Federal University of Santa Catarina, Florianópolis, 151p. (*in Portuguese*).
10. Mohamed, G. (1998) “Mechanical behavior at failure of concrete masonry”. Msc. Dissertation (Civil Engineering Program- PPGEC) – Federal University of Santa Catarina, Florianópolis, 1998, 178p. (*in Portuguese*).